

Time-Reversed Diffraction

Max S. Zolotarev

Center for Beam Physics, Lawrence Berkeley National Laboratory, Berkeley, CA 94720

Kirk T. McDonald

Joseph Henry Laboratories, Princeton University, Princeton, NJ 08544

(September 5, 1999; updated July 25, 2018)

1 Problem

In the usual formulation of the Kirchhoff diffraction integral [1], a scalar field with harmonic time dependence at angular frequency ω is deduced in a charge/current-free volume from knowledge of the field (or its normal derivative) on the bounding surface. In particular, the field is propagated forwards in time from the bounding surface to the desired observation point.

Construct a time-reversed version of the Kirchhoff integral in which the knowledge of the field on the bounding surface is propagated backwards in time into the volume.

Consider the example of an optical focus at the origin of a system whose optic axis is the z -axis. In the far field the Gaussian beam has cone angle $\theta_0 \equiv \sqrt{2}\sigma_\theta$, and the x -component of the electric field in a spherical coordinate system is given approximately by

$$E_x(r, \theta, \phi, t) = E(r)e^{i(kr-\omega t)}e^{-\theta^2/\theta_0^2}, \quad (1)$$

where $k = \omega/c$ and c is the speed of light. Deduce the field near the focus.

Since the Kirchhoff diffraction formalism requires the volume to be charge free, the time-reversed technique is not obviously applicable to cases where the source of the field is inside the volume. Nonetheless, the reader may find it instructive to apply the time-reversed diffraction integral to the example of an oscillating dipole at the origin.

2 The Kirchhoff Integral via Green's Theorem

A standard formulation of Kirchhoff's diffraction integral for a scalar field $\psi(\mathbf{x})$ with time dependence $e^{-i\omega t}$ is

$$\psi(\mathbf{x}) \approx \frac{k}{2\pi i} \oint_S \frac{e^{ikr'}}{r'} \psi(\mathbf{x}') d\text{Area}', \quad (2)$$

where the spherical waves $e^{i(kr'-\omega t)}/r'$ are outgoing, and r' is the magnitude of vector $\mathbf{r}' = \mathbf{x} - \mathbf{x}'$.

For a time-reversed formulation in which we retain the time dependence as $e^{-i\omega t}$, the spherical waves of interest are the incoming waves $e^{-i(kr'+\omega t)}/r'$. In brief, the desired time-reversed diffraction integral is obtained from eq. (2) on replacing i by $-i$:

$$\psi(\mathbf{x}) \approx \frac{ik}{2\pi} \oint_S \frac{e^{-ikr'}}{r'} \psi(\mathbf{x}') d\text{Area}'. \quad (3)$$

For completeness, we review the derivation of eqs. (2)-(3) via Green's theorem. See also, sec. 10.5 of ref. [2].

Green tells us that for any two well-behaved scalar fields ϕ and ψ ,

$$\int_V (\phi \nabla^2 \psi - \psi \nabla^2 \phi) d\text{Vol} = \oint_S (\phi \nabla' \psi - \psi \nabla' \phi) \cdot d\mathbf{S}', \quad (4)$$

where the surface element $d\mathbf{S}'$ is directed away from the closed surface S that bounds volume V .¹ We consider fields with harmonic time dependence at frequency ω , and assume the factor $e^{-i\omega t}$. The wave function of interest, ψ , obeys the Helmholtz wave equation,

$$\nabla^2 \psi + k^2 \psi = -4\pi g, \quad (5)$$

where $g(\mathbf{x}) e^{-i\omega t}$ describes the sources of ψ .

We choose function $\phi(\mathbf{x})$ to correspond to waves associated with a point source at \mathbf{x}' . That is,

$$\nabla^2 \phi + k^2 \phi = -4\pi \delta^3(\mathbf{x}' - \mathbf{x}) = -4\pi \delta(\mathbf{r}'). \quad (6)$$

The well-known solutions to this are the incoming and outgoing spherical waves,

$$\phi_{\pm}(\mathbf{x}, \mathbf{x}') = \frac{e^{\pm ikr'}}{r'}, \quad (7)$$

where the $+$ sign corresponds to the outgoing wave. We recall that

$$\nabla' r' = -\frac{\mathbf{r}'}{r'} = -\hat{\mathbf{n}}_o, \quad (8)$$

where $\hat{\mathbf{n}}_o$ points from \mathbf{x}' to the observer at \mathbf{x} . Then,

$$\nabla' \phi_{\pm} = \mp 4\pi i k \hat{\mathbf{n}}_o \left(1 \pm \frac{1}{ikr'} \right) \phi. \quad (9)$$

Inserting eqs. (5)-(9) into eq. (4), we find

$$\psi(\mathbf{x}) = \int_V g \frac{e^{\pm ikr'}}{r'} d\text{Vol}' - \frac{1}{4\pi} \oint_S \frac{e^{\pm ikr'}}{r'} \hat{\mathbf{n}}' \cdot \left[\nabla' \psi \pm ik \hat{\mathbf{n}}_o \left(1 \pm \frac{1}{ikr'} \right) \psi \right] d\text{Area}', \quad (10)$$

where the overall minus sign for the surface integral holds with the convention that volume V is exterior to the surface S and that $\hat{\mathbf{n}}'$ is the inward normal to the surface.

Consider also the case that volume V is interior to surface S . If all sources are contained in a finite volume then the surface integral in eq. (10) vanishes as that surface is taken to “infinity”. Hence, we obtain a solution for ψ in terms of its sources g as

$$\psi(\mathbf{x}, t) = \psi(\mathbf{x}) e^{-i\omega t} = \int_V g(\mathbf{x}') \frac{e^{-i\omega(t \mp r'/c)}}{r'} d\text{Vol}' = \int_V \frac{g(\mathbf{x}', t')}{r'} d\text{Vol}', \quad (11)$$

where V is any volume that encloses all of the sources, and $t' = t \mp r'/c$ is the retarded (advanced) time at the source point \mathbf{x}' . That is, the retarded (or advanced) solution emerges from the Green-Kirchhoff analysis (although this is typically not mentioned²).

¹Note that volume V can be either exterior or interior to the bounding surface S . In case volume V is exterior to surface S the surface element $d\mathbf{S}'$ is directed inwards.

²A noteworthy exception is sec. 8.1 of [3].

Equation (10) is typically applied to situations where there are no sources within volume V so the volume integral is zero. The meaning of the surface integral in eq. (10) is subtle when sources are present within volume V , because information as to the wavefunction ψ only on the surface does not clarify whether or not those sources are actually present. Thus, the surface integral in eq. (10) is, in general, nonzero even when sources are present, and must be interpreted with care. For an example, see sec. 2.6 below.

We now consider cases where the sources of the wave ψ are outside volume V and far from the boundary surface S , so that on the boundary ψ is well approximated as a spherical wave,

$$\psi(\mathbf{x}') \approx A \frac{e^{ikr_s}}{r_s}, \quad (12)$$

where r_s is the magnitude of the vector $\mathbf{r}_s = \mathbf{x}' - \mathbf{x}_s$ from the effective source point \mathbf{x}_s to the point \mathbf{x}' on the boundary surface. In this case,

$$\nabla' \psi = ik \hat{\mathbf{n}}_s \left(1 \pm \frac{1}{ikr_s} \right) \psi, \quad (13)$$

where $\hat{\mathbf{n}}_s = \mathbf{r}_s / r_s$.

We also suppose that the observation point is far from the boundary surface, so that $kr' \gg 1$ as well as $kr_s \gg 1$. Hence, we neglect the terms in $1/ikr'$ and $1/ikr_s$ to find

$$\psi(\mathbf{x}) = -\frac{ik}{4\pi} \int_S \frac{e^{\pm ikr'}}{r'} \hat{\mathbf{n}}' \cdot (\hat{\mathbf{n}}_s \pm \hat{\mathbf{n}}_o) \psi(\mathbf{x}') d\text{Area}'. \quad (14)$$

The usual formulation, eq. (2), of Kirchhoff's law is obtained using outgoing waves (+ signs), and the paraxial approximation that $\hat{\mathbf{n}}' \approx \hat{\mathbf{n}}_o \approx \hat{\mathbf{n}}_s$. The latter approximation tacitly assumes that the sources are outside volume V .

Here, we are interested in cases where the effective sources are outside the bounding surface S (so that V is the volume interior to that surface). Then, the paraxial approximation is $\hat{\mathbf{n}}' \approx \hat{\mathbf{n}}_o \approx -\hat{\mathbf{n}}_s$. When reconstructing $\psi(\mathbf{x}, t)$ from information on the boundary at time $t' > t$ via the incoming wave function, we use the $-$ signs in eq. (14) to find eq. (3).

3 A Plane Wave

The time-reversed Kirchhoff integral (3) for the x component of the electric field is

$$E_x(\text{obs, now}) = \frac{ik}{2\pi} \int \frac{e^{-ikr'}}{r'} E_x(r, \theta, \phi, \text{future}) d\text{Area}', \quad (15)$$

where r' is the distance from the observation point $\mathbf{r}_{\text{obs}} = (x, y, z)$ in rectangular coordinates to a point $\mathbf{r} = r(\sin \theta \cos \phi, \sin \theta \sin \phi, \cos \theta)$ on a sphere of radius r in the far field.

As a first example, consider a plane electromagnetic wave,

$$E_x = E_0 e^{i(kz - \omega t)} = E_0 e^{i(kr \cos \theta - \omega t)}, \quad (16)$$

where the second form holds in a spherical coordinate system (r, θ, ϕ) where θ is measured with respect to the z axis. We take the point of observation to be $(x, y, z) = (0, 0, r_0)$, and

evaluate the diffraction integral (15) over a sphere of radius $r \gg r_0$. In the exponential factor in the Kirchhoff integral, we approximate r' as

$$r' \approx r - \hat{\mathbf{r}} \cdot \mathbf{r}_{\text{obs}} = r - r_0 \cos \theta, \quad (17)$$

while in the denominator we approximate r' as r . Then,

$$\begin{aligned} E_x(\text{obs}) &\approx \frac{ik}{2\pi} \int_{-1}^1 r^2 d\cos\theta \int_0^{2\pi} d\phi \frac{e^{-ik(r-r_0\cos\theta)}}{r} E_0 e^{ikr\cos\theta} \\ &= \frac{r}{r+r_0} E_0 [e^{ikr_0} - e^{-ik(2r+r_0)}] \\ &\approx E_0 e^{ikr_0}, \end{aligned} \quad (18)$$

where we ignore the rapidly oscillating term $e^{-ik(2r+r_0)}$ as unphysical.

This verifies that the time-reversed diffraction formula works for a simple example.

4 The Transverse Field near a Laser Focus

We now consider the far field of a laser beam whose optic axis is the z axis with focal point at the origin. The polarization is along the x axis, and the electric field has Gaussian dependence on polar angle with characteristic angle $\theta_0 \ll 1$. Then, we can write

$$E_x(r, \theta, \phi) = E(r) e^{ikr} e^{-\theta^2/\theta_0^2}, \quad (19)$$

where $E(r)$ is the magnitude of the electric field on the optic axis at distance r from the focus. In the exponential factor in the Kirchhoff integral (15), r' is the distance from the observation point $\mathbf{r}_{\text{obs}} = (x, y, z)$ to a point $\mathbf{r} = r(\sin\theta\cos\phi, \sin\theta\sin\phi, \cos\theta)$ on the sphere. We approximate r' as

$$r' \approx r - \hat{\mathbf{r}} \cdot \mathbf{r}_{\text{obs}} = r - x \sin\theta \cos\phi - y \sin\theta \sin\phi - z \cos\theta, \quad (20)$$

while in the denominator we approximate r' as r . Inserting eqs. (19) and (20) into (15), we find

$$\begin{aligned} E_x(\text{obs}) &= \frac{ikrE(r)}{2\pi} \int_{-1}^1 e^{ikz\cos\theta} e^{-\theta^2/\theta_0^2} d\cos\theta \int_0^{2\pi} e^{ikx\sin\theta\cos\phi +iky\sin\theta\sin\phi} d\phi \\ &= ikrE(r) \int_{-1}^1 e^{ikz\cos\theta} e^{-\theta^2/\theta_0^2} J_0(k\rho\sin\theta) d\cos\theta, \end{aligned} \quad (21)$$

where

$$\rho = \sqrt{x^2 + y^2}, \quad (22)$$

and J_0 is the Bessel function of order zero.

Since we assume that the characteristic angle θ_0 of the laser beam is small, we can approximate $\cos\theta$ as $1 - \theta^2/2$ and $k\rho\sin\theta$ as $k\rho\theta$. Then, we have

$$\begin{aligned} E_x(\text{obs}) &\approx ikrE(r) e^{ikz} \int_0^\infty e^{-(2/\theta_0^2 + ikz)\theta^2/2} J_0\left(\sqrt{2}k\rho\sqrt{\theta^2/2}\right) d(\theta^2/2) \\ &= \frac{ik\theta_0^2 r E(r) e^{ikz} e^{-k^2\theta_0^2\rho^2/4(1+ik\theta_0^2 z/2)}}{2(1+ik\theta_0^2 z/2)}, \end{aligned} \quad (23)$$

where the Laplace transform, which is given explicitly in [4], can be evaluated using the series expansion for the Bessel function. This expression can be put in a more familiar form by introducing the Rayleigh range (depth of focus),

$$z_0 = \frac{2}{k\theta_0^2}, \quad (24)$$

and the so-called waist of the laser beam,

$$w_0 = \theta_0 z_0 = \frac{2}{k\theta_0}. \quad (25)$$

We define the electric field strength at the focus ($\rho = 0, z = 0$) to be E_0 , so we learn that the far-field strength is related by

$$E(r) = -i \frac{z_0}{r} E_0. \quad (26)$$

The factor $-i = e^{-i\pi/2}$ is the 90° Gouy phase shift between the focus and the far field. Then, the transverse component of the electric field near the focus is

$$\begin{aligned} E_x(x, y, z) &\approx E_0 \frac{e^{-\rho^2/w_0^2(1+iz/z_0)} e^{ikz}}{(1+iz/z_0)} \\ &= E_0 \frac{e^{-\rho^2/w_0^2(1+z^2/z_0^2)} e^{-i \tan^{-1} z/z_0} e^{i\rho^2 z/w_0^2 z_0(1+z^2/z_0^2)} e^{ikz}}{\sqrt{1+(z/z_0)^2}}. \end{aligned} \quad (27)$$

This is the usual form for the lowest-order mode of a linearly polarized Gaussian laser beam [5]. Figure 1 plots this field.

The Gaussian beam (27) could also be deduced by a similar argument using eq. (2), starting from the far field of the laser before the focus. The form (27) is symmetric in z except for a phase factor, and so is a solution to the problem of transporting a wave from $z = -r$ to $z = +r$ such that the functional dependence on ρ and z is invariant up to a phase factor. One of the earliest derivations [6] of the Gaussian beam was based on the formulation of this problem as an integral equation for the eigenfunction (27).

5 The Longitudinal Field near a Laser Focus

Far from the focus, the electric field $\mathbf{E}(\mathbf{r})$ is perpendicular to the radius vector \mathbf{r} . For a field linearly polarized in the x direction, there must also be a longitudinal component E_z related by

$$\mathbf{E} \cdot \hat{\mathbf{r}} = E_x \sin \theta \cos \phi + E_z \cos \theta = 0. \quad (28)$$

Thus, far from the focus,

$$E_z(\mathbf{r}) = -E_x(\mathbf{r}) \tan \theta \cos \phi. \quad (29)$$

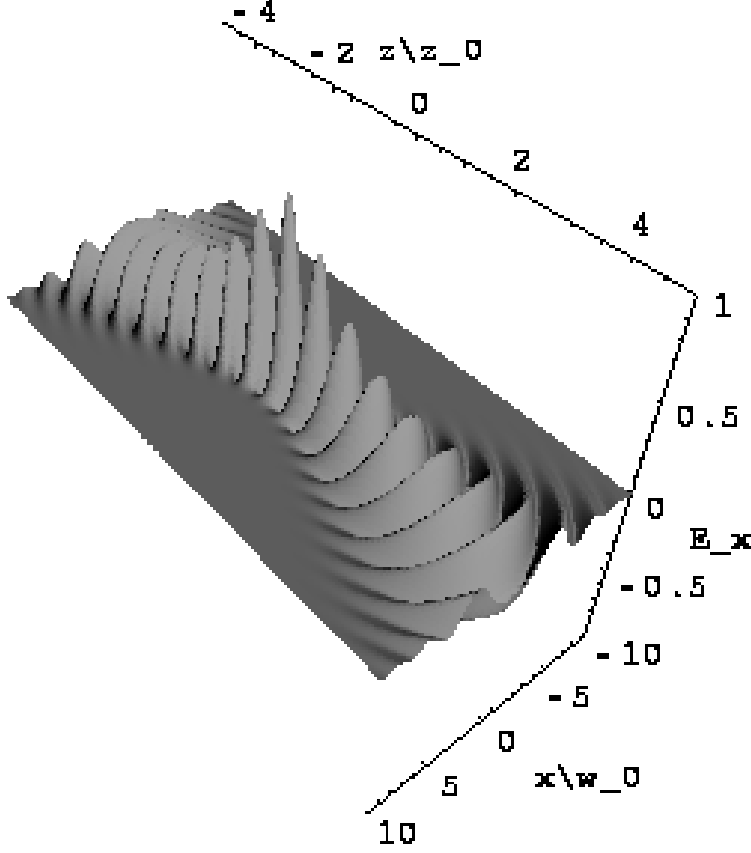

Figure 1: The electric field $E_x(x, 0, z)$ of a linearly polarized Gaussian beam with diffraction angle $\theta_0 = 0.45$.

Then, similarly to eqs. (15) and (21), we have

$$\begin{aligned}
E_z(\text{obs}) &= \frac{ik}{2\pi} \int \frac{e^{-ikr'}}{r'} E_z(\mathbf{r}) \, d\text{Area} \\
&= -\frac{ikrE(r)}{2\pi} \int_{-1}^1 e^{ikz \cos \theta} e^{-\theta^2/\theta_0^2} \tan \theta \, d\cos \theta \int_0^{2\pi} e^{ikx \sin \theta \cos \phi +iky \sin \theta \sin \phi} \cos \phi \, d\phi \\
&= -\frac{ikxz_0E_0}{\rho} \int_{-1}^1 e^{ikz \cos \theta} e^{-\theta^2/\theta_0^2} \tan \theta J_1(k\rho \sin \theta) \, d\cos \theta, \tag{30}
\end{aligned}$$

using eq. (3.937.2) of [7].

We again note that the integrand is significant only for small θ , so we can approximate eq. (30) as the Laplace transform

$$\begin{aligned}
E_z(x, y, z) &\approx -ik^2xz_0E_0e^{ikz} \sqrt{2} \int_0^\infty e^{-(2/\theta_0^2+ikz)\theta^2/2} \sqrt{\theta^2/2} J_1\left(\sqrt{2}k\rho\sqrt{\theta^2/2}\right) d(\theta^2/2) \\
&= -\frac{ik^2\theta_0^4xz_0E_0e^{ikz} e^{-\rho^2/w_0^2(1+iz/z_0)}}{4(1+iz/z_0)^2}
\end{aligned}$$

$$= -i\theta_0 \frac{x}{w_0} \frac{E_x(x, y, z)}{(1 + iz/z_0)}, \quad (31)$$

with E_x given by eq. (27). Figure 2 plots this field.

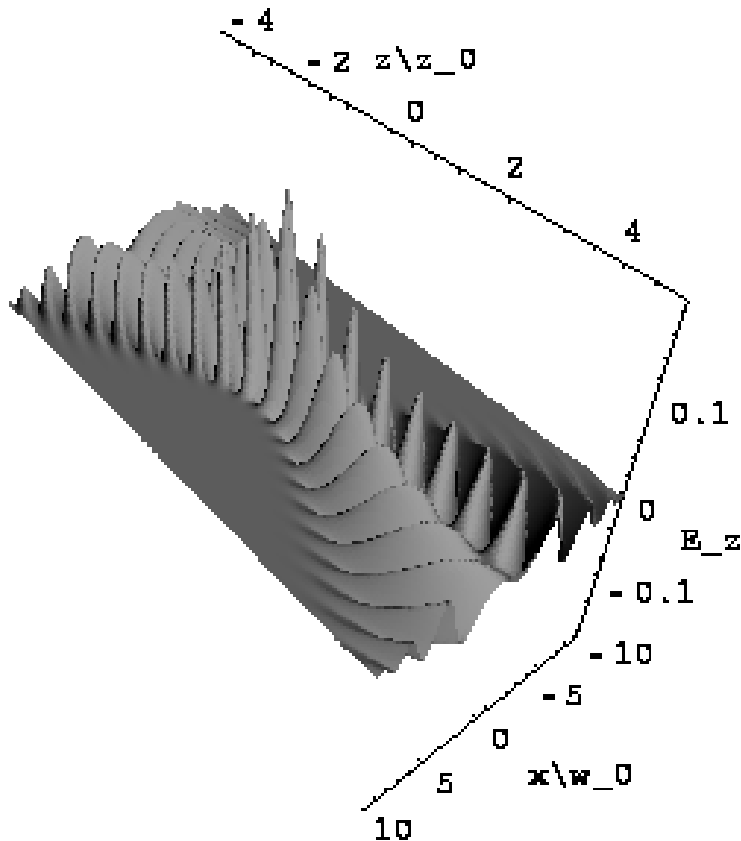

Figure 2: The electric field $E_z(x, 0, z)$ of a linearly polarized Gaussian beam with diffraction angle $\theta_0 = 0.45$.

Together, the electric field components given by eqs. (27) and (31) satisfy the Maxwell equation $\nabla \cdot \mathbf{E} = 0$ to order θ_0^2 [8, 9, 10].

6 Oscillating Dipole at the Origin

We cannot expect the Kirchhoff diffraction integral to apply to the example of an oscillating dipole, if our bounding surface surrounds the dipole. Let us see what happens if we try to use eq. (3) anyway.

The dipole is taken to be at the origin, with moment p along the x axis. Then, the radiation field has only the x -component

$$E_x = k^2 p \sin^2 \theta_x \frac{e^{ikr}}{r}, \quad (32)$$

where θ_x is the angle between the x axis and a radius vector to the observer. In a spherical coordinate system (r, θ, ϕ) that favors the z axis, we have $\cos \theta_x = \sin \theta \cos \phi$, and the x component of the radiation field at the sphere of radius r is

$$E_x(r, \theta, \phi) = k^2 p (1 - \sin^2 \theta \cos^2 \phi) \frac{e^{ikr}}{r}. \quad (33)$$

We consider an observer near the origin at $(x, y, z) = (0, 0, r_0)$, for which $\sin \theta_x = 1$, and so the electric field, including the near field terms,³ is

$$E_x(\text{obs}) = k^3 p e^{ikr_0} \left(\frac{1}{kr_0} + \frac{i}{k^2 r_0^2} - \frac{1}{k^3 r_0^3} \right). \quad (34)$$

We now attempt to reconstruct this field near the origin from its value on a sphere of radius $r \gg r_0$ using the time-reversed Kirchhoff integral (3).

In the time-reversed Kirchhoff integral (3), we make the usual approximation that $r' = r - r_0 \cos \theta$ in the exponential factor, but $r' = r$ in the denominator. Then, using eq. (33) we have

$$\begin{aligned} E_x(\text{obs}) &\approx \frac{ik}{2\pi} \int_{-1}^1 r^2 d \cos \theta \int_0^{2\pi} d\phi \frac{e^{-ik(r-r_0 \cos \theta)}}{r} k^2 p (1 - \sin^2 \theta \cos^2 \phi) \frac{e^{ikr}}{r} \\ &= \frac{ik^3 p}{2} \int_{-1}^1 d \cos \theta e^{ikr_0 \cos \theta} (1 + \cos^2 \theta) \\ &= k^3 p \left[e^{ikr_0} \left(\frac{1}{kr_0} + \frac{i}{k^2 r_0^2} - \frac{1}{k^3 r_0^3} \right) - e^{-ikr_0} \left(\frac{1}{kr_0} - \frac{i}{k^2 r_0^2} - \frac{1}{k^3 r_0^3} \right) \right]. \quad (35) \end{aligned}$$

The first, outgoing wave in the third line of eq. (35) has the desired form (34), while the second, incoming wave is that associated with an oscillating dipole of strength $-p \hat{\mathbf{x}}$ at the origin.⁴

In using eq. (3) we have tacitly assumed that there are no sources within the sphere of radius r . In that case waves must both enter and exit the surface of the sphere, and its interior must include both incoming and outgoing waves. Thus, eq. (34) is a valid solution for the fields inside the sphere, assuming it to contain no sources, given only knowledge on its surface.

Furthermore, if we have knowledge of the fields only on the surface of the sphere, we do not know whether the sources are inside or outside the sphere.⁵

It is impressive to this author that if we have the additional knowledge that the fields (33) on the surface of the sphere are associated only with outgoing waves (which implies that there are sources within the sphere) we can obtain a detailed reconstruction of the fields within the sphere by using eq. (3) and then discarding the predicted incoming waves.⁶

³See, for example, sec. 9.2 of [2], or prob. 2 of [11].

⁴See, for example, prob. 12 of [11].

⁵The argument at the top of p. 3 suggests that the result of the surface integral (35) should actually have been zero, since the sources of the fields (33) are within the volume that is interior to the surface. However, since a given set of fields on a surface can be consistent with sources being on either side of that surface, we cannot expect the surface integral to vanish just because the sources might have been inside the surface.

⁶Perhaps this technique could be used to reconstruct the fields outside a surface known to contain all sources, using information about the fields on a more distant surface.

A Appendix: Review of Vector Diffraction Theory

A better approximation to diffraction of electromagnetic waves is to use vector forms of the Kirchhoff integral.

An early insight of Stokes [12] is that the transverse character of electromagnetic waves should permit the use of diffraction integrals involving only transverse vector components.

The first work on vector diffraction theory appears to be that of Love [13], who used a curious mixture of fields and generalized vector potentials (see also [14, 15]). He did demonstrate a useful result as to the minimum amount of information about \mathbf{E} and \mathbf{B} required on a closed surface S to determine the fields “within” the enclosed volume V . Here, we follow the argument in sec. 9.2 of [3].

Suppose at some time t there exist two different solutions, $\mathbf{E}_1, \mathbf{B}_1$ and $\mathbf{E}_2, \mathbf{B}_2$, for the fields in volume V . Consider the difference fields, $\mathbf{E}_d = \mathbf{E}_1 - \mathbf{E}_2$ and $\mathbf{B}_d = \mathbf{B}_1 - \mathbf{B}_2$, which satisfy the source-free Maxwell’s equations,

$$\nabla \cdot \mathbf{E}_d = 0, \quad \nabla \cdot \mathbf{B}_d = 0, \quad (36)$$

$$\nabla \times \mathbf{E}_d = -\frac{1}{c} \frac{\partial \mathbf{B}_d}{\partial t}, \quad \nabla \times \mathbf{B}_d = \frac{1}{c} \frac{\partial \mathbf{E}_d}{\partial t}. \quad (37)$$

Then, following Poynting [16], we have

$$\begin{aligned} \nabla \cdot (\mathbf{E}_d \times \mathbf{B}_d) &= \mathbf{B}_d \cdot \nabla \times \mathbf{E}_d - \mathbf{E}_d \cdot \nabla \times \mathbf{B}_d \\ &= -\frac{1}{c} \left(\mathbf{B}_d \cdot \frac{\partial \mathbf{B}_d}{\partial t} + \mathbf{E}_d \cdot \frac{\partial \mathbf{E}_d}{\partial t} \right) = -\frac{1}{2c} \frac{\partial}{\partial t} (E_d^2 + B_d^2), \end{aligned} \quad (38)$$

and hence,

$$\begin{aligned} -\frac{1}{2c} \frac{d}{dt} \int_V (E_d^2 + B_d^2) d\text{Vol} &= \oint_S (\mathbf{E}_d \times \mathbf{B}_d) \cdot \hat{\mathbf{n}} d\text{Area} \\ &= \oint_S (\mathbf{B}_d \times \hat{\mathbf{n}}) \cdot \mathbf{E}_d d\text{Area} = \oint_S (\hat{\mathbf{n}} \times \mathbf{E}_d) \cdot \mathbf{B}_d d\text{Area}. \end{aligned} \quad (39)$$

Thus, if either the tangential component of \mathbf{E} or \mathbf{B} is known on surface S , then either $\hat{\mathbf{n}} \times \mathbf{E}_d$ or $\hat{\mathbf{n}} \times \mathbf{B}_d$ vanishes everywhere on this surface, and the volume integral is equal to its initial value all later times. In problems of practical interest, there is some initial time at which the fields are zero, such that the initial value of the volume integral of the difference fields is also zero. Then, it follows that the difference fields will be zero at all later times, and unique solutions for the electromagnetic fields \mathbf{E} and \mathbf{B} within volume V can be obtained from knowledge of the tangential component of either \mathbf{E} or \mathbf{B} on the bounding surface S .⁷

A version of vector Kirchhoff integrals that use only the fields \mathbf{E} and \mathbf{B} (of time dependence $e^{-i\omega t}$) was given by Stratton and Chu [21] (see also Appendix A.1),

⁷While the electromagnetic fields \mathbf{E} and \mathbf{B} have a total of six components at any point, knowledge of only two of these suffices to determine the others. This result is plausible in that the fields can be written as a sum of plane waves, each of which has only two independent vector components. For related discussion, see [17, 18, 19, 20].

$$\mathbf{E}(\mathbf{x}) = \int_V \left(\frac{ik}{c} \mathbf{J}(\mathbf{x}') \frac{e^{\pm ikr}}{r} + \rho(\mathbf{x}') \nabla' \frac{e^{\pm ikr}}{r} \right) d\text{Vol}' \quad (40)$$

$$- \frac{1}{4\pi} \oint_S \left\{ ik[\hat{\mathbf{n}}' \times \mathbf{B}(\mathbf{x}')] \frac{e^{\pm ikr}}{r} + [\hat{\mathbf{n}}' \times \mathbf{E}(\mathbf{x}')] \times \nabla' \frac{e^{\pm ikr}}{r} + [\hat{\mathbf{n}}' \cdot \mathbf{E}(\mathbf{x}')] \nabla' \frac{e^{\pm ikr}}{r} \right\} d\text{Area}',$$

$$\mathbf{B}(\mathbf{x}) = \frac{1}{c} \int_V \mathbf{J}(\mathbf{x}') \times \nabla' \frac{e^{\pm ikr}}{r} d\text{Vol}' \quad (41)$$

$$+ \frac{1}{4\pi} \oint_S \left\{ ik[\hat{\mathbf{n}}' \times \mathbf{E}(\mathbf{x}')] \frac{e^{\pm ikr}}{r} - [\hat{\mathbf{n}}' \times \mathbf{B}(\mathbf{x}')] \times \nabla' \frac{e^{\pm ikr}}{r} - [\hat{\mathbf{n}}' \cdot \mathbf{B}(\mathbf{x}')] \nabla' \frac{e^{\pm ikr}}{r} \right\} d\text{Area}',$$

where $\hat{\mathbf{n}}'$ is the outward unit vector normal to surface S , and $r = |\mathbf{x} - \mathbf{x}'|$. The forms (40)-(41) use all six components of \mathbf{E} and \mathbf{B} on the surface, while only two of these are actually needed. Hence, there must be alternative forms of the integrals.⁸

One such set of alternative integrals has been given by Kottler [26, 27] and again by Franz [28, 29, 30] using a dyadic Green's function (see also Appendices A.3 and A.4),^{9,10}

$$\mathbf{E}(\mathbf{x}) = \int_V \left(\frac{ik}{c} \mathbf{J}(\mathbf{x}') \frac{e^{\pm ikr}}{r} + \rho(\mathbf{x}') \nabla' \frac{e^{\pm ikr}}{r} \right) d\text{Vol}' + \frac{i}{\omega} \oint_S (\mathbf{J} \cdot \hat{\mathbf{n}}') \nabla' \frac{e^{\pm ikr}}{r} d\text{Area}'$$

$$- \frac{1}{4\pi} \nabla \times \oint_S \left\{ \hat{\mathbf{n}}' \times \mathbf{E}(\mathbf{x}') \frac{e^{\pm ikr}}{r} + \frac{i}{k} \nabla \times [\hat{\mathbf{n}}' \times \mathbf{B}(\mathbf{x}')] \frac{e^{\pm ikr}}{r} \right\} d\text{Area}', \quad (42)$$

$$\mathbf{B}(\mathbf{x}) = \frac{1}{c} \int_V \mathbf{J}(\mathbf{x}') \times \nabla' \frac{e^{\pm ikr}}{r} d\text{Vol}'$$

$$- \frac{1}{4\pi} \nabla \times \oint_S \left\{ \hat{\mathbf{n}}' \times \mathbf{B}(\mathbf{x}') \frac{e^{\pm ikr}}{r} - \frac{i}{k} \nabla \times [\hat{\mathbf{n}}' \times \mathbf{E}(\mathbf{x}')] \frac{e^{\pm ikr}}{r} \right\} d\text{Area}'. \quad (43)$$

However, these forms still require knowledge of four vector components on the surface S , rather than only two. We can reduce the number of needed components to three, *i.e.*, those of either \mathbf{E} or \mathbf{B} , via the Maxwell equations

$$\mathbf{E}(\mathbf{x}') = \frac{i}{k} \nabla' \times \mathbf{B}(\mathbf{x}') + \frac{4\pi i}{\omega} \mathbf{J}(\mathbf{x}'), \quad \mathbf{B}(\mathbf{x}') = -\frac{i}{k} \nabla' \times \mathbf{E}(\mathbf{x}'). \quad (44)$$

A.1 Example: A Plane Wave

To illustrate the use of Kottler's formulation, (42)-(43), we consider a plane wave,

$$\mathbf{E} = E_0 e^{i(kz - \omega t)} \hat{\mathbf{x}}, \quad \mathbf{B} = E_0 e^{i(kz - \omega t)} \hat{\mathbf{y}}, \quad (45)$$

⁸An interesting aspect of eqs. (40)-(41) is that the volume integrals over the sources can be used to find the fields when the surface S is removed to "infinity". These volume integrals have come to be called the "Jefimenko" equations, although they appear in Stratton's book [3], the paper of Stratton and Chu [21], and can be traced as far back as in papers by Ignatowsky [23, 24]. See also [25]. These integrals are described by Franz [30] as "well-known" in that they follow quickly from $\mathbf{E} = -\nabla V + ik\mathbf{A}$, and $\mathbf{B} = \nabla \times \mathbf{A}$ using the advanced or retarded potentials $V = \int_V (\rho e^{\pm ikr}/r) d\text{Vol}$ and $\mathbf{A} = \int_V (\mathbf{J} e^{\pm ikr}/cr) d\text{Vol}$.

⁹The operations involving ∇ , which act only on the factor r , should be performed before the surface integrations in eqs. (42)-(43).

¹⁰The surface integral involving $\mathbf{J} \cdot \hat{\mathbf{n}}'$ does not appear in the expressions of Kottler and Franz. It would be nonzero only if the surface S includes a nonconducting medium, such as a hypothetical, perfectly absorbing "black" screen.

and take the surface S to be the plane $z = 0$ plus a hemisphere at “infinity” at positive z . We presume that there is no contribution from the hemispherical surface to the computation of the fields at an observation point $(0, 0, z > 0)$, so that eqs. (42)-(43) yield (using the retarded secondary waves),

$$\mathbf{E}(0, 0, z) e^{i\omega t} = \frac{E_0}{4\pi} \nabla \times \oint_{z'=0} \left\{ \hat{\mathbf{y}} \frac{e^{ikr}}{r} - \frac{i}{k} \nabla \times \hat{\mathbf{x}} \frac{e^{ikr}}{r} \right\} d\text{Area}', \quad (46)$$

$$\mathbf{B}(0, 0, z) e^{i\omega t} = -\frac{E_0}{4\pi} \nabla \times \oint_{z'=0} \left\{ \hat{\mathbf{x}} \frac{e^{ikr}}{r} - \frac{i}{k} \nabla \times \hat{\mathbf{y}} \frac{e^{ikr}}{r} \right\} d\text{Area}', \quad (47)$$

where $r = \sqrt{x'^2 + y'^2 + z^2}$ and we have noted that $\hat{\mathbf{n}}' = -\hat{\mathbf{z}}$. If we take

$$\oint_{z'=0} \frac{e^{ikr}}{r} d\text{Area}' = K - \frac{2\pi e^{ikz}}{ik}, \quad (48)$$

for some constant K , then

$$\mathbf{E}(0, 0, z) e^{i\omega t} = -\frac{E_0}{2ik} \nabla \times \left\{ \hat{\mathbf{y}} e^{ikz} - \frac{i}{k} \nabla \times \hat{\mathbf{x}} e^{ikz} \right\} = -\frac{E_0}{ik} \nabla \times \hat{\mathbf{y}} e^{ikz} = E_0 \hat{\mathbf{x}} e^{ikz}, \quad (49)$$

$$\mathbf{B}(0, 0, z) e^{i\omega t} = \frac{E_0}{2ik} \nabla \times \left\{ \hat{\mathbf{x}} e^{ikz} + \frac{i}{k} \nabla \times \hat{\mathbf{y}} e^{ikz} \right\} = \frac{E_0}{ik} \nabla \times \hat{\mathbf{x}} e^{ikz} = E_0 \hat{\mathbf{y}} e^{ikz}, \quad (50)$$

as expected (which validates eq. (48)).

A.2 Smythe’s Formulation

Smythe [31, 32] has given a formulation for the special case that there exist a perfectly conducting plane screen, say at $z = 0$ with apertures, and all charges and currents not on that screen are to one side of it, say $z < 0$. Then, in Kottler’s formulation (43)-(44) we can again take the surface S to be the plane $z = 0$ plus a hemisphere at “infinity” at positive z . We presume that there is no contribution from the hemispherical surface to the computation of the fields at an observation point $(0, 0, z > 0)$ to find (noting that $\hat{\mathbf{n}}' = -\hat{\mathbf{z}}'$ on the plane $z' = 0$),

$$\mathbf{E}(\mathbf{x}) = \frac{1}{4\pi} \nabla \times \oint_{z'=0} \left\{ \hat{\mathbf{z}} \times \mathbf{E}(\mathbf{x}') \frac{e^{ikr}}{r} + \frac{i}{k} \nabla \times [\hat{\mathbf{z}} \times \mathbf{B}(\mathbf{x}')] \frac{e^{ikr}}{r} \right\} d\text{Area}', \quad (51)$$

$$\mathbf{B}(\mathbf{x}) = \frac{1}{4\pi} \nabla \times \oint_{z'=0} \left\{ \hat{\mathbf{z}} \times \mathbf{B}(\mathbf{x}') \frac{e^{ikr}}{r} - \frac{i}{k} \nabla \times [\hat{\mathbf{z}} \times \mathbf{E}(\mathbf{x}')] \frac{e^{ikr}}{r} \right\} d\text{Area}'. \quad (52)$$

As $\hat{\mathbf{z}} \times \mathbf{E}(z = 0)$ is a tangential to the plane $z = 0$, it must vanish next to the perfect conductor (but not in the apertures).

Smythe’s argument is, in effect, that the two terms in the integrand of eq. (51) make equal contributions, such that

$$\mathbf{E}(\mathbf{x}) = \frac{1}{2\pi} \nabla \times \oint_{z'=0} \hat{\mathbf{z}} \times \mathbf{E}(\mathbf{x}') \frac{e^{ikr}}{r} d\text{Area}' = \frac{i}{2\pi k} \nabla \times \nabla \times \oint_{z'=0} \hat{\mathbf{z}} \times \mathbf{B}(\mathbf{x}') \frac{e^{ikr}}{r} d\text{Area}'. \quad (53)$$

Then, using eq. (44), and comparing with eq. (52),

$$\begin{aligned}
\mathbf{B}(\mathbf{x}) &= \frac{1}{2\pi ik} \nabla \times \nabla \times \oint_{z'=0} \hat{\mathbf{z}} \times \mathbf{E}(\mathbf{x}') \frac{e^{ikr}}{r} d\text{Area}' \\
&= \frac{1}{2\pi} \nabla \times \oint_{z'=0} \hat{\mathbf{z}} \times \mathbf{B}(\mathbf{x}') \frac{e^{ikr}}{r} d\text{Area}'. \tag{54}
\end{aligned}$$

Smythe's formulation comes close to realizing Love's insight that the electromagnetic fields \mathbf{E} and \mathbf{B} within volume V can be obtained from knowledge only of the tangential component of either \mathbf{E} or \mathbf{B} on the bounding surface S .

If the screen were not present but the sources elsewhere remained the same, Smythe's relations (53)-(54) would apply to the fields in the case, which we label as the incident fields \mathbf{E}^i and \mathbf{B}^i . When the screen is present the total fields can be written as the sum of the incident fields and scattered fields, $\mathbf{E} = \mathbf{E}^i + \mathbf{E}^s$ and $\mathbf{B} = \mathbf{B}^i + \mathbf{B}^s$. It follows that Smythe's relations (53)-(54) also hold for the scattered fields \mathbf{E}^s and \mathbf{B}^s . That is, these relations hold separately for the total fields, the incident fields and the scattered fields.

An argument for Smythe's formulation is given in sec. 10.7 of [2], and also in [33], that appears to be based on the physically unreasonable assumption that no currents flow between one side and the other of a thin plane screen. Smythe does not appear to make this assumption (which does seem to be valid for plane waves of normal incidence).

A.3 Derivation of the Stratton-Chu Equations

Following Love [13], Stratton and Chu [21] invoke a vector form of Green's second identity,

$$\begin{aligned}
& \int_V [\mathbf{P} \cdot \nabla' \times (\nabla' \times \mathbf{Q}) - \mathbf{Q} \cdot \nabla' \times (\nabla' \times \mathbf{P})] d\text{Vol}' \\
&= \oint_S [\mathbf{Q} \times (\nabla' \times \mathbf{P}) - \mathbf{P} \times (\nabla' \times \mathbf{Q})] \cdot \hat{\mathbf{n}}' d\text{Area}' \\
&= - \oint_S [\hat{\mathbf{n}}' \times (\nabla' \times \mathbf{P}) \cdot \mathbf{Q} + \hat{\mathbf{n}}' \times \mathbf{P} \cdot (\nabla' \times \mathbf{Q})] d\text{Area}', \quad (55)
\end{aligned}$$

for any two reasonably well behaved vector fields \mathbf{P} and \mathbf{Q} .

We first take $\mathbf{P} = \mathbf{E}$ and $\mathbf{Q} = G(\mathbf{x}, \mathbf{x}') \mathbf{q}$, where \mathbf{q} is an arbitrary constant vector, and

$$G(\mathbf{x}, \mathbf{x}') = \frac{e^{\pm ik|\mathbf{x}-\mathbf{x}'|}}{4\pi|\mathbf{x}-\mathbf{x}'|} = \frac{e^{\pm ikr}}{4\pi r}, \quad (56)$$

is the free-space Green's function for the scalar Helmholtz equation

$$(\nabla^2 + k^2)G(\mathbf{x}, \mathbf{x}') = (\nabla'^2 + k^2)G(\mathbf{x}, \mathbf{x}') = -\delta^3(\mathbf{x} - \mathbf{x}'). \quad (57)$$

Then,

$$\nabla \times \mathbf{P} = ik\mathbf{B}, \quad \nabla \times (\nabla \times \mathbf{P}) = k^2\mathbf{E} + \frac{4\pi ik}{c}\mathbf{J}, \quad (58)$$

and

$$\nabla \times \mathbf{Q} = \nabla G \times \mathbf{q}, \quad \nabla \times (\nabla \times \mathbf{Q}) = \nabla(\mathbf{q} \cdot \nabla G) + k^2 G \mathbf{q} + \delta^3(\mathbf{x} - \mathbf{x}') \mathbf{q}. \quad (59)$$

Using eqs. (56) and (58)-(59) in eq. (55), we have

$$\begin{aligned}
\mathbf{q} \cdot \mathbf{E}(\mathbf{x}) &= \frac{ik}{c} \mathbf{q} \cdot \int_V \mathbf{J} \frac{e^{\pm ikr}}{r} d\text{Vol}' - \frac{\mathbf{q}}{4\pi} \cdot \int_V (\mathbf{E} \cdot \nabla') \nabla' \frac{e^{\pm ikr}}{r} d\text{Vol}' \\
&\quad - \frac{ik\mathbf{q}}{4\pi} \cdot \oint_S \hat{\mathbf{n}}' \times \mathbf{B} \frac{e^{\pm ikr}}{r} d\text{Area}' - \frac{\mathbf{q}}{4\pi} \cdot \oint_S (\hat{\mathbf{n}}' \times \mathbf{E}) \times \nabla' \frac{e^{\pm ikr}}{r} d\text{Area}', \quad (60)
\end{aligned}$$

using the identity $(\mathbf{a} \times \mathbf{b}) \cdot (\mathbf{c} \times \mathbf{d}) = \mathbf{d} \cdot [(\mathbf{a} \times \mathbf{b}) \times \mathbf{c}]$. Integrating the second volume integral by parts,

$$- \int_V (\mathbf{E} \cdot \nabla') \nabla' \frac{e^{\pm ikr}}{r} d\text{Vol}' = \int_V (\nabla' \cdot \mathbf{E}) \nabla' \frac{e^{\pm ikr}}{r} d\text{Vol}' - \oint_S (\mathbf{E} \cdot \hat{\mathbf{n}}') \nabla' \frac{e^{\pm ikr}}{r} d\text{Area}', \quad (61)$$

using the first Maxwell equation $\nabla' \cdot \mathbf{E} = 4\pi\rho$, and noting that the vector \mathbf{q} is arbitrary, we arrive at eq. (40),

$$\begin{aligned}
\mathbf{E}(\mathbf{x}) &= \frac{ik}{c} \int_V \mathbf{J} \frac{e^{\pm ikr}}{r} d\text{Vol}' + \int_V \rho \nabla' \frac{e^{\pm ikr}}{r} d\text{Vol}' \\
&\quad - \frac{1}{4\pi} \oint_S \left\{ ik \hat{\mathbf{n}}' \times \mathbf{B} \frac{e^{\pm ikr}}{r} + (\hat{\mathbf{n}}' \times \mathbf{E}) \times \nabla' \frac{e^{\pm ikr}}{r} + (\mathbf{E} \cdot \hat{\mathbf{n}}') \nabla' \frac{e^{\pm ikr}}{r} \right\} d\text{Area}'. \quad (40)
\end{aligned}$$

Taking instead $\mathbf{P} = \mathbf{B}$, then

$$\nabla \times \mathbf{P} = -ik\mathbf{E} + \frac{4\pi}{c}\mathbf{J}, \quad \nabla \times (\nabla \times \mathbf{P}) = k^2\mathbf{B} + \frac{4\pi}{c}\nabla \times \mathbf{J}, \quad (62)$$

and eq. (55) leads to

$$\begin{aligned} \mathbf{q} \cdot \mathbf{B}(\mathbf{x}) &= \frac{1}{c}\mathbf{q} \cdot \int_V \nabla' \times \mathbf{J} \frac{e^{\pm ikr}}{r} d\text{Vol}' - \frac{\mathbf{q}}{4\pi} \cdot \int_V (\mathbf{B} \cdot \nabla') \nabla' \frac{e^{\pm ikr}}{r} d\text{Vol}' \\ &+ \frac{ik\mathbf{q}}{4\pi} \cdot \oint_S \hat{\mathbf{n}}' \times \mathbf{E} \frac{e^{\pm ikr}}{r} d\text{Area}' - \frac{\mathbf{q}}{c} \cdot \oint_S \hat{\mathbf{n}}' \times \mathbf{J} \frac{e^{\pm ikr}}{r} d\text{Area}' \\ &- \frac{\mathbf{q}}{4\pi} \cdot \oint_S (\hat{\mathbf{n}}' \times \mathbf{B}) \times \nabla' \frac{e^{\pm ikr}}{r} d\text{Area}'. \end{aligned} \quad (63)$$

Integrating the volume integrals by parts, we have

$$\int_V \nabla' \times \mathbf{J} \frac{e^{\pm ikr}}{r} d\text{Vol}' = \int_V \mathbf{J} \times \nabla' \frac{e^{\pm ikr}}{r} d\text{Vol}' + \oint_S \hat{\mathbf{n}}' \times \mathbf{J} \frac{e^{\pm ikr}}{r} d\text{Area}', \quad (64)$$

and

$$- \int_V (\mathbf{B} \cdot \nabla') \nabla' \frac{e^{\pm ikr}}{r} d\text{Vol}' = \int_V (\nabla' \cdot \mathbf{B}) \nabla' \frac{e^{\pm ikr}}{r} d\text{Vol}' - \oint_S (\mathbf{B} \cdot \hat{\mathbf{n}}') \nabla' \frac{e^{\pm ikr}}{r} d\text{Area}', \quad (65)$$

from which eq. (41) follows, since $\nabla' \cdot \mathbf{B} = 0$,

$$\begin{aligned} \mathbf{B}(\mathbf{x}) &= \frac{1}{c} \int_V \mathbf{J} \times \nabla' \frac{e^{\pm ikr}}{r} d\text{Vol}' \\ &+ \frac{1}{4\pi} \oint_S \left\{ ik \hat{\mathbf{n}}' \times \mathbf{E} \frac{e^{\pm ikr}}{r} - (\hat{\mathbf{n}}' \times \mathbf{B}) \times \nabla' \frac{e^{\pm ikr}}{r} - (\mathbf{B} \cdot \hat{\mathbf{n}}') \nabla' \frac{e^{\pm ikr}}{r} \right\} d\text{Area}'. \end{aligned} \quad (41)$$

A.4 Transformation from the Stratton-Chu Equations to Kottler's Equations

Tai [34] has noted that eqs. (40)-(41) can be transformed by taking their curls, and using the third and fourth Maxwell equations for fields with time dependence $e^{-i\omega t}$ in the form

$$\mathbf{E} = \frac{4\pi}{ikc}\mathbf{J} - \frac{1}{ik}\nabla \times \mathbf{B}, \quad \mathbf{B} = \frac{1}{ik}\nabla \times \mathbf{E}. \quad (66)$$

Then, recalling that ∇' can be replaced by $-\nabla$ in eqs. (40)-(41), that $\nabla' \cdot \mathbf{J} = ikc\rho$ and that $(\nabla'^2 + k^2)(e^{\pm ikr}/r) = -4\pi\delta^3(\mathbf{x} - \mathbf{x}')$, the curl of eq. (41) leads to

$$\begin{aligned} \mathbf{E}(\mathbf{x}) &= \frac{4\pi}{ikc}\mathbf{J}(\mathbf{x}) - \frac{1}{ikc}\nabla \times \int_V \mathbf{J} \times \nabla' \frac{e^{\pm ikr}}{r} d\text{Vol}' \\ &\quad - \frac{1}{4\pi ik}\nabla \times \oint_S \left\{ ik \hat{\mathbf{n}}' \times \mathbf{E} \frac{e^{\pm ikr}}{r} + (\hat{\mathbf{n}}' \times \mathbf{B}) \times \nabla \frac{e^{\pm ikr}}{r} + (\mathbf{B} \cdot \hat{\mathbf{n}}') \nabla \frac{e^{\pm ikr}}{r} \right\} d\text{Area}' \\ &= \frac{4\pi}{ikc}\mathbf{J}(\mathbf{x}) + \frac{1}{ikc} \int_V [\mathbf{J}\nabla'^2 - (\mathbf{J} \cdot \nabla')\nabla'] \frac{e^{\pm ikr}}{r} d\text{Vol}' \\ &\quad - \frac{1}{4\pi}\nabla \times \oint_S \hat{\mathbf{n}}' \times \mathbf{E} \frac{e^{\pm ikr}}{r} d\text{Area}' - \frac{i}{4\pi k}\nabla \times \nabla \times \oint_S \hat{\mathbf{n}}' \times \mathbf{B} \frac{e^{\pm ikr}}{r} d\text{Area}' \\ &= \frac{ik}{c} \int_V \mathbf{J} \frac{e^{\pm ikr}}{r} d\text{Vol}' + \int_V \rho \nabla' \frac{e^{\pm ikr}}{r} d\text{Vol}' + \frac{i}{\omega} \oint_S (\mathbf{J} \cdot \hat{\mathbf{n}}') \nabla' \frac{e^{\pm ikr}}{r} d\text{Area}' \\ &\quad - \frac{1}{4\pi}\nabla \times \oint_S \hat{\mathbf{n}}' \times \mathbf{E} \frac{e^{\pm ikr}}{r} d\text{Area}' - \frac{i}{4\pi k}\nabla \times \nabla \times \oint_S \hat{\mathbf{n}}' \times \mathbf{B} \frac{e^{\pm ikr}}{r} d\text{Area}'. \quad (42) \end{aligned}$$

Similarly, the curl of eq. (40) leads to

$$\begin{aligned} \mathbf{B}(\mathbf{x}) &= \frac{1}{ik}\nabla \times \int_V \left(\frac{ik}{c}\mathbf{J} - \rho\nabla \right) \frac{e^{\pm ikr}}{r} d\text{Vol}' \\ &\quad - \frac{1}{4\pi ik}\nabla \times \oint_S \left\{ ik \hat{\mathbf{n}}' \times \mathbf{B} \frac{e^{\pm ikr}}{r} - (\hat{\mathbf{n}}' \times \mathbf{E}) \times \nabla \frac{e^{\pm ikr}}{r} - (\mathbf{E} \cdot \hat{\mathbf{n}}') \nabla \frac{e^{\pm ikr}}{r} \right\} d\text{Area}' \\ &= \frac{1}{c} \int_V \mathbf{J} \times \nabla' \frac{e^{\pm ikr}}{r} d\text{Vol}' \\ &\quad - \frac{1}{4\pi}\nabla \times \oint_S \hat{\mathbf{n}}' \times \mathbf{B} \frac{e^{\pm ikr}}{r} d\text{Area}' + \frac{i}{4\pi k}\nabla \times \nabla \times \oint_S \hat{\mathbf{n}}' \times \mathbf{E} \frac{e^{\pm ikr}}{r} d\text{Area}'. \quad (43) \end{aligned}$$

A.5 Derivation of Kottler's Equations via Bivectors and Dyadics

We follow Tai [35] in using the notation of bivectors and dyadics to give a compact derivation of Franz' results (42)-(43).¹¹

We introduce the notion of a bivector only to compactify the notation for similar pairs of equations involving the electric and magnetic fields. Given any two vectors, or vector

¹¹Bivectors were defined by Hamilton on p. 665 of [36]. Dyadics may have been first defined by Gibbs on p. 40 of [37], which work also discusses bivectors on pp. 76-82.

expressions, \mathbf{a} and \mathbf{b} , we combine them into a bivector $\underline{\mathbf{c}}$ according to

$$\underline{\mathbf{c}} = \mathbf{a} + h \mathbf{b}, \quad (67)$$

where $h = \sqrt{-1} = i$ is the separation constant¹² (and not Planck's constant), which has the role of identifying the second of the two vector constituents of a bivector.¹³ Then, if we know that $\mathbf{a} = \mathbf{d}$ and $\mathbf{b} = \mathbf{e}$ we can summarize this as $\underline{\mathbf{c}} = \underline{\mathbf{g}}$ where $\underline{\mathbf{g}} = \mathbf{d} + h \mathbf{e}$.

We define the electromagnetic field bivector $\underline{\mathbf{F}}$ as,¹⁴

$$\underline{\mathbf{F}} = \mathbf{E} + h \mathbf{B}, \quad (68)$$

such that the third and fourth of Maxwell's equations (for fields with time dependence $e^{-i\omega t}$),

$$\nabla \times \mathbf{E} = ik\mathbf{B}, \quad \nabla \times \mathbf{B} = -ik\mathbf{E} + \frac{4\pi}{c}\mathbf{J}, \quad (69)$$

can be written in bivector form as

$$\nabla \times \underline{\mathbf{F}} = -ikh\underline{\mathbf{F}} + \frac{4\pi}{c}h\mathbf{J}, \quad (70)$$

using the convention that $\nabla \odot \underline{\mathbf{F}} = \nabla \odot \mathbf{E} + h \nabla \odot \mathbf{B}$ for operation \odot either \cdot or \times , noting that $h\underline{\mathbf{F}} = -\mathbf{B} + h\mathbf{E}$, and restricting the discussion to media in which the (relative) permittivity and permeability, ϵ and μ , are unity.¹⁵

Taking the curl of eq. (70), we find,

$$\nabla \times (\nabla \times \underline{\mathbf{F}}) = -ikh \nabla \times \underline{\mathbf{F}} + \frac{4\pi}{c}h \nabla \times \mathbf{J} = k^2 \underline{\mathbf{F}} + \frac{4\pi}{c}(ik\mathbf{J} + h \nabla \times \mathbf{J}). \quad (71)$$

We define a source bivector $\underline{\mathbf{g}}$ according to

$$\underline{\mathbf{g}} = ik\mathbf{J} + h \nabla \times \mathbf{J}, \quad (72)$$

such that the bivector version of Helmholtz equations for the electromagnetic fields is

$$\nabla \times (\nabla \times \underline{\mathbf{F}}) - k^2 \underline{\mathbf{F}} = \nabla(\nabla \cdot \underline{\mathbf{F}}) - (\nabla^2 + k^2)\underline{\mathbf{F}} = \frac{4\pi}{c}\underline{\mathbf{g}}. \quad (73)$$

The next step is to construct a free-space Green's function for eq. (73) with a point source at an arbitrary location \mathbf{x}' . As $\nabla \cdot \underline{\mathbf{F}}$ is nonzero when sources are present, eq. (72) does not separate into scalar equations for its x , y and z components. Rather, the desired Green's

¹²While Hamilton and Gibbs took h to be $i = \sqrt{-1}$, Bateman (sec. 2 of [38]) points out that in some cases it is advantageous to write $h = \pm i$ in that bivector equations can then be decomposed into a pair of vector equations by equating the coefficients of either the i or the \pm . In both conventions, $h^2 = -1$.

¹³A bivector is closely related to a six vector as introduced by Sommerfeld in sec. 1 of [39].

¹⁴The electromagnetic field bivector (68) was first used by Riemann in lectures given around 1860, but only published in 1901, p. 348 of [40]. It was also used, perhaps independently, by Silberstein (1907), eq. (9) of [41], where Hamilton is cited for the invention of the bivector.

¹⁵Note also that the scalar $\underline{\mathbf{F}} \cdot \underline{\mathbf{F}} = E^2 - B^2 + 2h \mathbf{E} \cdot \mathbf{B}$ is a Lorentz invariant of the electromagnetic fields.

function is a tensor, as discussed in Appendix I of [42], which can be expressed in dyadic notation as

$$\mathbf{G}_0(\mathbf{x}, \mathbf{x}') = \mathbf{G}_0(\mathbf{x}', \mathbf{x}) = \left(\mathbf{I} + \frac{\nabla \nabla}{k^2} \right) \frac{e^{\pm ikr}}{r} = \left(\mathbf{I} + \frac{\nabla' \nabla'}{k^2} \right) \frac{e^{\pm ikr}}{r}, \quad (74)$$

where $\mathbf{I} = \hat{\mathbf{x}}\hat{\mathbf{x}} + \hat{\mathbf{y}}\hat{\mathbf{y}} + \hat{\mathbf{z}}\hat{\mathbf{z}}$ is the unit dyad, and $r = |\mathbf{x} - \mathbf{x}'|$ as before. This dyadic Green's function, which vanishes at infinity, is a solution to the equation

$$\nabla \times (\nabla \times \mathbf{G}_0(\mathbf{x}, \mathbf{x}')) - k^2 \mathbf{G}_0(\mathbf{x}, \mathbf{x}') = \nabla (\nabla \cdot \mathbf{G}_0(\mathbf{x}, \mathbf{x}')) - (\nabla^2 + k^2) \mathbf{G}_0(\mathbf{x}, \mathbf{x}') = \mathbf{I} \delta^3(\mathbf{x} - \mathbf{x}'). \quad (75)$$

To see this, begin by taking the divergence of the first form of eq. (75),

$$-k^2 \nabla \cdot \mathbf{G}_0(\mathbf{x}, \mathbf{x}') = \nabla \cdot \mathbf{I} \delta^3(\mathbf{x} - \mathbf{x}') = \nabla \delta^3(\mathbf{x} - \mathbf{x}') = -\nabla' \delta^3(\mathbf{x} - \mathbf{x}'). \quad (76)$$

Using this in the second form of eq. (75), we obtain

$$(\nabla^2 + k^2) \mathbf{G}_0(\mathbf{x}, \mathbf{x}') = - \left(\mathbf{I} - \frac{\nabla \nabla'}{k^2} \right) \delta^3(\mathbf{x} - \mathbf{x}') = - \left(\mathbf{I} + \frac{\nabla \nabla}{k^2} \right) \delta^3(\mathbf{x} - \mathbf{x}'). \quad (77)$$

We consider a solution of the form

$$\mathbf{G}_0(\mathbf{x}, \mathbf{x}') = \left(\mathbf{I} + \frac{\nabla \nabla}{k^2} \right) G(\mathbf{x}, \mathbf{x}'), \quad (78)$$

which satisfies eq. (77) provided

$$(\nabla^2 + k^2) G(\mathbf{x}, \mathbf{x}') = -\delta^3(\mathbf{x} - \mathbf{x}'). \quad (79)$$

Thus, $G(\mathbf{x}, \mathbf{x}')$ is the well-known Green's function for the scalar Helmholtz equation (79), namely

$$G(\mathbf{x}, \mathbf{x}') = \frac{e^{\pm ik|\mathbf{x} - \mathbf{x}'|}}{4\pi |\mathbf{x} - \mathbf{x}'|} = \frac{e^{\pm ikr}}{4\pi r}, \quad (80)$$

and the desired dyadic Green's function is given by eq. (74).

Finally, we use the vector form of Green's second identity, eq. (55), taking $\mathbf{P} = \overline{\mathbf{F}}$ and $\mathbf{Q} = \mathbf{G}_0$.¹⁶ Then, using eqs. (70), (73) and (75), we obtain

$$\begin{aligned} & \int_V \left\{ \overline{\mathbf{F}} \cdot [k^2 \mathbf{G}_0(\mathbf{x} - \mathbf{x}') + \mathbf{I} \delta^3(\mathbf{x} - \mathbf{x}')] - \mathbf{G}_0(\mathbf{x} - \mathbf{x}') \cdot \left(k^2 \overline{\mathbf{F}} + \frac{4\pi}{c} \underline{\mathbf{g}} \right) \right\} d\text{Vol}' \\ &= - \oint_S \left\{ \hat{\mathbf{n}}' \times \left(-ikh \overline{\mathbf{F}} + \frac{4\pi}{c} h \mathbf{J} \right) \cdot \mathbf{G}_0(\mathbf{x} - \mathbf{x}') + \hat{\mathbf{n}}' \times \overline{\mathbf{F}} \cdot [\nabla' \times \mathbf{G}_0(\mathbf{x} - \mathbf{x}')] \right\} d\text{Area}' \end{aligned} \quad (81)$$

That is,

$$\begin{aligned} \overline{\mathbf{F}}(\mathbf{x}) &= \frac{4\pi}{c} \int_V \underline{\mathbf{g}} \cdot \mathbf{G}_0(\mathbf{x} - \mathbf{x}') d\text{Vol}' \\ &+ \oint_S \hat{\mathbf{n}}' \times \overline{\mathbf{F}} \cdot [-\nabla \times \mathbf{G}_0(\mathbf{x} - \mathbf{x}') + ikh \mathbf{G}_0(\mathbf{x} - \mathbf{x}')] d\text{Area}' \\ &- \frac{4\pi h}{c} \oint_S \hat{\mathbf{n}}' \times \mathbf{J} \cdot \mathbf{G}_0(\mathbf{x} - \mathbf{x}') d\text{Area}', \end{aligned} \quad (82)$$

¹⁶The vector \mathbf{Q} in eq. (55) could also be a dyadic \mathbf{Q} , as can be confirmed by writing $\mathbf{Q} = \mathbf{Q} \cdot \mathbf{q}$, where \mathbf{q} is an arbitrary, constant vector.

noting that the operator $-\nabla$ has the same effect as ∇' when acting on $G_0(\mathbf{x} + \mathbf{x}')$.

Equation (82) is relatively compact, but its implications for the fields \mathbf{E} and \mathbf{B} are not immediately evident. Recalling the definitions (68) and (72) for the bivectors $\overline{\mathbf{F}}$ and $\overline{\mathbf{g}}$ and eq. (74) for the dyadic Green's function $G_0(\mathbf{x} - \mathbf{x}')$ we learn that

$$\begin{aligned}
\mathbf{E}(\mathbf{x}) &= \frac{ik}{c} \int_V \mathbf{J} \cdot \left(1 + \frac{\nabla\nabla}{k^2}\right) \frac{e^{\pm ikr}}{r} d\text{Vol}' \\
&\quad - \oint_S \left[(\hat{\mathbf{n}}' \times \mathbf{E}) \cdot \left(1 + \frac{\nabla\nabla}{k^2}\right) + ik \hat{\mathbf{n}}' \times \mathbf{B} \cdot \left(1 + \frac{\nabla\nabla}{k^2}\right) \right] d\text{Area}' \\
&= \frac{ik}{c} \int_V \left(\mathbf{J} + (\mathbf{J} \cdot \nabla') \frac{\nabla'}{k^2} \right) \frac{e^{\pm ikr}}{r} d\text{Vol}' \\
&\quad - \frac{1}{4\pi} \oint_S \left[\nabla \times (\hat{\mathbf{n}}' \times \mathbf{E}) + (\hat{\mathbf{n}}' \times \mathbf{E} \cdot \nabla) \nabla \times \frac{\nabla}{k^2} \right] \frac{e^{\pm ikr}}{r} d\text{Area}' \\
&\quad - \frac{ik}{4\pi} \oint_S \left[\hat{\mathbf{n}}' \times \mathbf{B} + (\hat{\mathbf{n}}' \times \mathbf{B} \cdot \nabla) \frac{\nabla}{k^2} \right] \frac{e^{\pm ikr}}{r} d\text{Area}' \\
&= \frac{ik}{c} \int_V \left(\mathbf{J} - (\nabla' \cdot \mathbf{J}) \frac{\nabla'}{k^2} \right) \frac{e^{\pm ikr}}{r} d\text{Vol}' + \frac{i}{\omega} \oint_S (\mathbf{J} \cdot \hat{\mathbf{n}}') \nabla' \frac{e^{\pm ikr}}{r} d\text{Area}' \\
&\quad - \frac{1}{4\pi} \nabla \times \oint_S \hat{\mathbf{n}}' \times \mathbf{E} \frac{e^{\pm ikr}}{r} d\text{Area}' \\
&\quad - \frac{ik}{4\pi} \oint_S \left[-\hat{\mathbf{n}}' \times \mathbf{B} \frac{\nabla^2}{k^2} + (\hat{\mathbf{n}}' \times \mathbf{B} \cdot \nabla) \frac{\nabla}{k^2} \right] \frac{e^{\pm ikr}}{r} d\text{Area}' \\
&= \int_V \left(\frac{ik}{c} \mathbf{J} + \rho \nabla' \right) \frac{e^{\pm ikr}}{r} d\text{Vol}' + \frac{i}{\omega} \oint_S (\mathbf{J} \cdot \hat{\mathbf{n}}') \nabla' \frac{e^{\pm ikr}}{r} d\text{Area}' \\
&\quad - \frac{1}{4\pi} \nabla \times \oint_S \hat{\mathbf{n}}' \times \mathbf{E} \frac{e^{\pm ikr}}{r} d\text{Area}' - \frac{i}{4\pi k} \nabla \times \nabla \times \oint_S \hat{\mathbf{n}}' \times \mathbf{B} \frac{e^{\pm ikr}}{r} d\text{Area}', \tag{42}
\end{aligned}$$

noting that $\nabla \cdot \mathbf{J} = i\omega\rho$ expresses charge conservation for currents with time dependence $e^{-i\omega t}$, and that $(\nabla^2 + k^2)(e^{\pm ikr}/r) = 0$ for points \mathbf{x}' on surface S . Similarly,

$$\begin{aligned}
\mathbf{B}(\mathbf{x}) &= \frac{1}{c} \int_V \nabla' \times \mathbf{J} \cdot \left(1 + \frac{\nabla\nabla}{k^2}\right) \frac{e^{\pm ikr}}{r} d\text{Vol}' \\
&\quad + \oint_S \left[-(\hat{\mathbf{n}}' \times \mathbf{B}) \cdot \nabla \times \left(1 + \frac{\nabla\nabla}{k^2}\right) + ik \hat{\mathbf{n}}' \times \mathbf{E} \cdot \left(1 + \frac{\nabla\nabla}{k^2}\right) \right] d\text{Area}' \\
&\quad - \frac{1}{c} \oint_S \hat{\mathbf{n}}' \times \mathbf{J} \cdot \left(1 + \frac{\nabla\nabla}{k^2}\right) \frac{e^{\pm ikr}}{r} d\text{Area}' \\
&= \frac{1}{c} \int_V \left(\nabla' \times \mathbf{J} + [(\nabla' \times \mathbf{J}) \cdot \nabla'] \frac{\nabla'}{k^2} \right) \frac{e^{\pm ikr}}{r} d\text{Vol}' \\
&\quad - \frac{1}{4\pi} \oint_S \left[\nabla \times (\hat{\mathbf{n}}' \times \mathbf{B}) + (\hat{\mathbf{n}}' \times \mathbf{B} \cdot \nabla) \nabla \times \frac{\nabla}{k^2} \right] \frac{e^{\pm ikr}}{r} d\text{Area}' \\
&\quad + \frac{ik}{4\pi} \oint_S \left[\hat{\mathbf{n}}' \times \mathbf{E} + (\hat{\mathbf{n}}' \times \mathbf{E} \cdot \nabla) \frac{\nabla}{k^2} \right] \frac{e^{\pm ikr}}{r} d\text{Area}'
\end{aligned}$$

$$\begin{aligned}
& -\frac{1}{c} \oint_S \left[\hat{\mathbf{n}}' \times \mathbf{J} + (\hat{\mathbf{n}}' \times \mathbf{J} \cdot \nabla') \frac{\nabla'}{k^2} \right] \frac{e^{\pm ikr}}{r} d\text{Area}' \\
= & \frac{1}{c} \int_V \left(\mathbf{J} \times \nabla' - (\nabla' \cdot \nabla' \times \mathbf{J}) \frac{\nabla'}{k^2} \right) \frac{e^{\pm ikr}}{r} d\text{Vol}' \\
& + \frac{1}{c} \oint_S \left[\hat{\mathbf{n}}' \times \mathbf{J} + (\hat{\mathbf{n}}' \times \mathbf{J} \cdot \nabla') \frac{\nabla'}{k^2} \right] \frac{e^{\pm ikr}}{r} d\text{Area}' \\
& - \frac{1}{4\pi} \nabla \times \oint_S \hat{\mathbf{n}}' \times \mathbf{B} \frac{e^{\pm ikr}}{r} d\text{Area}' \\
& + \frac{ik}{4\pi} \oint_S \left[-\hat{\mathbf{n}}' \times \mathbf{E} \frac{\nabla'^2}{k^2} + (\hat{\mathbf{n}}' \times \mathbf{E} \cdot \nabla') \frac{\nabla'}{k^2} \right] \frac{e^{\pm ikr}}{r} d\text{Area}' \\
& - \frac{1}{c} \oint_S \left[\hat{\mathbf{n}}' \times \mathbf{J} + (\hat{\mathbf{n}}' \times \mathbf{J} \cdot \nabla') \frac{\nabla'}{k^2} \right] \frac{e^{\pm ikr}}{r} d\text{Area}' \\
= & \frac{1}{c} \int_V \mathbf{J} \times \nabla' \frac{e^{\pm ikr}}{r} d\text{Vol}' \\
& - \frac{1}{4\pi} \nabla \times \oint_S \hat{\mathbf{n}}' \times \mathbf{B} \frac{e^{\pm ikr}}{r} d\text{Area}' + \frac{i}{4\pi k} \nabla \times \nabla \times \oint_S \hat{\mathbf{n}}' \times \mathbf{E} \frac{e^{\pm ikr}}{r} d\text{Area}'. \quad (43)
\end{aligned}$$

Care is needed in evaluating integrals like $\int_V \mathbf{G}_0(\mathbf{x} - \mathbf{x}') \cdot \mathbf{J} d\text{Vol}'$ at points \mathbf{x} inside the region of nonzero field \mathbf{J} . See, for example, [43, 44].

A.6 Kottler's Equations Via a Vector Green's Function

Another formulation of the vector Kirchhoff integrals has been given by Mentzner [45] by taking the vector \mathbf{Q} in eq. (55) to be the vector Green's function

$$\mathbf{Q} = \mathbf{G} = \nabla G(\mathbf{x}, \mathbf{x}') \times \mathbf{q} = \nabla \times G(\mathbf{x}, \mathbf{x}') \mathbf{q} = \nabla \times \frac{e^{\pm ikr}}{4\pi r} \mathbf{q}, \quad (83)$$

where \mathbf{q} is an arbitrary constant vector.¹⁷ Then,

$$\nabla \times \mathbf{G} = \nabla \times (\nabla G \times \mathbf{q}) = (\mathbf{q} \cdot \nabla) \nabla G - \mathbf{q} \nabla^2 G = (\mathbf{q} \cdot \nabla) \nabla G + \mathbf{q} [k^2 G + \delta^3(\mathbf{x} - \mathbf{x}')]. \quad (84)$$

and

$$\nabla \times (\nabla \times \mathbf{G}) = \nabla [k^2 G + \delta^3(\mathbf{x} - \mathbf{x}')] \times \mathbf{q}. \quad (85)$$

Taking $\mathbf{P} = \mathbf{B}$ in eq. (55), we now obtain

$$\begin{aligned} & \int_V \left\{ \mathbf{B} \cdot \nabla' [k^2 G + \delta^3(\mathbf{x} - \mathbf{x}')] \times \mathbf{q} - \nabla' G \times \mathbf{q} \cdot \left(k^2 \mathbf{B} + \frac{4\pi}{c} \nabla' \times \mathbf{J} \right) \right\} d\text{Vol}' \\ &= \mathbf{q} \cdot \int_V \mathbf{B} \times \nabla' \delta^3(\mathbf{x} - \mathbf{x}') d\text{Vol}' - \frac{4\pi}{c} \mathbf{q} \cdot \int_V \nabla G \times (\nabla' \times \mathbf{J}) d\text{Vol}' \\ &= \mathbf{q} \cdot \nabla \times \mathbf{B}(\mathbf{x}) - \frac{4\pi}{c} q_i \int_V \frac{\partial G}{\partial x_j} \frac{\partial J_j}{\partial x'_i} d\text{Vol}' + \frac{4\pi}{c} q_i \int_V \frac{\partial G}{\partial x_j} \frac{\partial J_i}{\partial x'_j} d\text{Vol}' \\ &= \mathbf{q} \cdot \left(-ik\mathbf{E} + \frac{4\pi}{c} \mathbf{J} \right) - \frac{4\pi}{c} \mathbf{q} \cdot \int_S (\nabla G \cdot \hat{\mathbf{n}}') \mathbf{J} d\text{Area}' - \frac{4\pi}{c} q_i \int_V \frac{\partial^2 G}{\partial x'_i \partial x'_j} J_j d\text{Vol}' \\ & \quad + \frac{4\pi}{c} \mathbf{q} \cdot \int_S (\nabla \cdot \mathbf{J}) \hat{\mathbf{n}}' d\text{Area}' + \frac{4\pi}{c} \mathbf{q} \cdot \int_V \nabla^2 G \mathbf{J} d\text{Vol}' \\ &= \mathbf{q} \cdot \left(-ik\mathbf{E} + \frac{4\pi}{c} \mathbf{J} \right) - \mathbf{q} \cdot \nabla \times \int_S \hat{\mathbf{n}}' \times \frac{4\pi}{c} \mathbf{J} d\text{Area}' - \frac{4\pi}{c} \mathbf{q} \cdot \int_S (\mathbf{J} \cdot \hat{\mathbf{n}}') \nabla' G d\text{Area}' \\ & \quad - \frac{4\pi}{c} \mathbf{q} \cdot \int_V (\nabla' \cdot \mathbf{J}) \nabla' G d\text{Vol}' - \frac{4\pi}{c} \mathbf{q} \cdot \int_V [k^2 G + \delta^3(\mathbf{x} - \mathbf{x}')] \mathbf{J} d\text{Vol}' \\ &= \mathbf{q} \cdot -ik\mathbf{E} - \mathbf{q} \cdot \nabla \times \int_S \hat{\mathbf{n}}' \times \frac{4\pi}{c} \mathbf{J} d\text{Area}' - \frac{4\pi}{c} \mathbf{q} \cdot \int_S (\mathbf{J} \cdot \hat{\mathbf{n}}') \nabla' G d\text{Area}' \\ & \quad + \frac{4\pi i\omega}{c} \mathbf{q} \cdot \int_V \rho \nabla' G d\text{Vol}' - \frac{4\pi k^2}{c} \mathbf{q} \cdot \int_V \mathbf{J} G d\text{Vol}' \\ &= - \oint_S \left\{ \hat{\mathbf{n}}' \times \left(-ik\mathbf{E} + \frac{4\pi}{c} \mathbf{J} \right) \cdot (\nabla' G \times \mathbf{q}) + \hat{\mathbf{n}}' \times \mathbf{B} \cdot [\nabla' \times (\nabla' G \times \mathbf{q})] \right\} d\text{Area}' \\ &= \oint_S \hat{\mathbf{n}}' \times \left(-ik\mathbf{E} + \frac{4\pi}{c} \mathbf{J} \right) \cdot (\nabla G \times \mathbf{q}) d\text{Area}' - \oint_S \hat{\mathbf{n}}' \times \mathbf{B} \cdot [\nabla \times (\nabla G \times \mathbf{q})] d\text{Area}' \\ &= -\mathbf{q} \cdot \nabla \times \oint_S \hat{\mathbf{n}}' \times \left(-ik\mathbf{E} + \frac{4\pi}{c} \mathbf{J} \right) G d\text{Area}' - \mathbf{q} \cdot \nabla \times \nabla \times \oint_S \hat{\mathbf{n}}' \times \mathbf{B} G d\text{Area}', \quad (86) \end{aligned}$$

¹⁷For what it's worth, \mathbf{G} is the magnetic field $\mathbf{B}(\mathbf{x})$ from an oscillating, point electric dipole at \mathbf{x}' with moment $\mathbf{p} = i\mathbf{q}/k$.

where to obtain the last equality we note that $\mathbf{p} \cdot \nabla \times (\nabla G \times \mathbf{q}) = \mathbf{q} \cdot \nabla \times (\nabla \times \mathbf{p} G)$ when the operator ∇ does not act on either vectors \mathbf{p} or \mathbf{q} . Comparing the fifth and eighth equalities, which hold for arbitrary \mathbf{q} , we again arrive at Kottler's eq. (42),

$$\begin{aligned} \mathbf{E}(\mathbf{x}) = & \frac{ik}{c} \int_V \mathbf{J} \frac{e^{\pm ikr}}{r} d\text{Vol}' + \int_V \rho \nabla' \frac{e^{\pm ikr}}{r} d\text{Vol}' + \frac{i}{\omega} \oint_S (\mathbf{J} \cdot \hat{\mathbf{n}}') \nabla' \frac{e^{\pm ikr}}{r} d\text{Area}' \\ & - \frac{1}{4\pi} \nabla \times \oint_S \hat{\mathbf{n}}' \times \mathbf{E} \frac{e^{\pm ikr}}{r} d\text{Area}' - \frac{i}{4\pi k} \nabla \times \nabla \times \oint_S \hat{\mathbf{n}}' \times \mathbf{B} \frac{e^{\pm ikr}}{r} d\text{Area}'. \end{aligned} \quad (42)$$

By a similar exercise with $\mathbf{P} = \mathbf{E}$ we again obtain Kottler's eq. (43).

References

- [1] G. Kirchhoff, *Zur Theorie der Lichtstrahlen*, Ann. Phys. **18**, 663 (1883), http://physics.princeton.edu/~mcdonald/examples/EM/kirchhoff_ap_18_663_83.pdf
- [2] J.D. Jackson, *Classical Electrodynamics*, 3rd ed. (Wiley, 1999), http://physics.princeton.edu/~mcdonald/examples/EM/jackson_ce3_99.pdf
- [3] J.A. Stratton *Electromagnetic Theory* (McGraw-Hill, New York, 1941), http://physics.princeton.edu/~mcdonald/examples/EM/stratton_electromagnetic_theory.pdf
- [4] W. Magnus and F. Oberhettinger, *Functions of Mathematical Physics* (Springer-Verlag, Berlin, 1943; reprinted by Chelsea Publishing Company, New York, 1949), pp. 131-132.
- [5] See, for example, sec. 14.5 of P.W. Milonni and J.H. Eberly, *Lasers* (Wiley Interscience, New York, 1988).
- [6] G.D. Boyd and J.P. Gordon, *Confocal Multimode Resonator for Millimeter Through Optical Wavelength Masers*, Bell Sys. Tech. J. **40**, 489-509 (1961), http://physics.princeton.edu/~mcdonald/examples/optics/boyd_bstj_40_489_61.pdf
- [7] I.S. Gradshteyn and I.M. Ryzhik, *Table of Integrals, Series, and Products*, 5th ed. (Academic Press, 1994), http://physics.princeton.edu/~mcdonald/examples/EM/gradshteyn_80.pdf
- [8] M. Lax, W.H. Louisell and W.B. McKnight, *From Maxwell to paraxial wave optics*, Phys. Rev. A **11**, 1365-1370 (1975), http://physics.princeton.edu/~mcdonald/examples/optics/lax_pra_11_1365_75.pdf
- [9] L.W. Davis, *Theory of electromagnetic beams*, Phys. Rev. A **19**, 1177-1179 (1979), http://physics.princeton.edu/~mcdonald/examples/optics/davis_pra_19_1177_79.pdf
- [10] J.P. Barton and D.R. Alexander, *Fifth-order corrected electromagnetic field components for a fundamental Gaussian beam*, J. Appl. Phys. **66**, 2800-2802 (1989), http://physics.princeton.edu/~mcdonald/examples/optics/barton_jap_66_2800_89.pdf
- [11] K.T. McDonald, *Electrodynamics Problem Set 8*, <http://physics.princeton.edu/~mcdonald/examples/ph501set8.pdf>

- [12] G.G. Stokes, *On the Dynamical Theory of Diffraction*, Trans. Camb. Phil. Soc. **9**, 1 (1849), http://physics.princeton.edu/~mcdonald/examples/optics/stokes_tcps_9_1_49.pdf
- [13] A.E.H. Love, *The Integration of the Equations of Propagation of Electric Waves*, Phil. Trans. Roy. Soc. London **197**, 1 (1901), http://physics.princeton.edu/~mcdonald/examples/EM/love_ptrsl_197_1_01.pdf
- [14] H.M. Macdonald, *Electric Waves*, (Cambridge U. Press, 1902), http://physics.princeton.edu/~mcdonald/examples/EM/macdonald_electric_waves_02.pdf
- [15] S.A. Schelkunoff, *Some Equivalence Theorems of Electromagnetics and Their Application to Radiation Problems*, Bell Sys. Tech. J. **15**, 92 (1936), http://physics.princeton.edu/~mcdonald/examples/EM/schelkunoff_bstj_15_92_36.pdf
- [16] J.H. Poynting, *On the Transfer of Energy in the Electromagnetic Field*, Phil. Trans. Roy. Soc. London **175**, 343 (1884), http://physics.princeton.edu/~mcdonald/examples/EM/poynting_ptrsl_175_343_84.pdf
- [17] E.T. Whittaker, *On an Expression of the Electromagnetic Field Due to Electrons by means of Two Scalar Potential Functions*, Proc. London Math. Soc. **1**, 367 (1904), http://physics.princeton.edu/~mcdonald/examples/EM/whittaker_plms_1_367_04.pdf
- [18] H.S. Green and E. Wolf, *A Scalar Representation of Electromagnetic Fields*, Proc. Phys. Soc. **A66**, 1129 (1953), http://physics.princeton.edu/~mcdonald/examples/EM/green_pps_a66_1129_53.pdf
- [19] A. Nisbet, *Hertzian electromagnetic potentials and associated gauge transformations*, Proc. Roy. Soc. London **A231**, 250 (1955), http://physics.princeton.edu/~mcdonald/examples/EM/nisbet_prlsa_231_250_55.pdf
- [20] E. Wolf, *A Scalar Representation of Electromagnetic Fields: II*, Proc. Phys. Soc. **A74**, 269 (1959), http://physics.princeton.edu/~mcdonald/examples/EM/wolf_pps_a74_269_59.pdf
- [21] J.A. Stratton and L.J. Chu, *Diffraction Theory of Electromagnetic Waves*, Phys. Rev. **56**, 99 (1939), http://physics.princeton.edu/~mcdonald/examples/EM/stratton_pr_56_99_39.pdf
- [22] J. Larmor, *On the Mathematical Expression of the Principle of Huygens*, Proc. London Math. Soc. **1**, 1 (1904), http://physics.princeton.edu/~mcdonald/examples/EM/larmor_plms_1_1_04.pdf
- [23] W. von Ignatowsky, *Reflexion elektromagnetischer Wellen an einem Draht*, Ann. Phys. **18**, 495 (1905), http://physics.princeton.edu/~mcdonald/examples/EM/ignatowsky_ap_18_495_05.pdf
- [24] W. von Ignatowsky, *Diffraction und Reflexion, abgeleitet aus den Maxwell'schen Gleichungen*, Ann. Phys. **23**, 875 (1907), **25**, 99 (1908), http://physics.princeton.edu/~mcdonald/examples/EM/ignatowsky_ap_25_99_08.pdf
- [25] K.T. McDonald, *The Relation between Expressions for Time-Dependent Electromagnetic Fields given by Jefimenko and by Panofsky and Phillips* (Dec. 5, 1995), <http://physics.princeton.edu/~mcdonald/examples/jefimenko.pdf>

- [26] F. Kottler, *Elektromagnetische Theorie der Beugung an schwarzen Schirmen*, Ann. Phys. **71**, 457 (1923), http://physics.princeton.edu/~mcdonald/examples/EM/kottler_ap_71_457_23.pdf
- [27] F. Kottler, *Diffraction at a Black Screen. Part II: Electromagnetic Theory*, Prog. Opt. **6**, 331 (1967), http://physics.princeton.edu/~mcdonald/examples/EM/kottler_po_6_331_67.pdf
- [28] W. Franz, *Zur Formulierung des Huygensschen Prinzips*, Z. Naturforschg. **3a**, 500 (1948), http://physics.princeton.edu/~mcdonald/examples/EM/franz_zn_3a_500_48.pdf
- [29] W. Franz, *Zur Theorie der Beugung*, Z. Phys. **125**, 563 (1949), http://physics.princeton.edu/~mcdonald/examples/EM/franz_zp_125_563_49.pdf
- [30] W. Franz, *On the Theory of Diffraction*, Proc. Phys. Soc. **63**, 925 (1950), http://physics.princeton.edu/~mcdonald/examples/EM/franz_pps_63_925_50.pdf
- [31] W.R. Smythe, *The Double Current Sheet in Diffraction*, Phys. Rev. **72**, 1066 (1947), http://physics.princeton.edu/~mcdonald/examples/EM/smythe_pr_72_1066_47.pdf
- [32] W.R. Smythe, *Static and Dynamic Electricity*, 3rd ed. (McGraw-Hill, 1968), sec. 12.18, http://physics.princeton.edu/~mcdonald/examples/EM/smythe_12-18.pdf
- [33] A. Drezet, J.C. Wohl and S. Huant, *Diffraction of light by a planar aperture in a metallic screen*, J. Math. Phys. **47**, 072901 (2006), http://physics.princeton.edu/~mcdonald/examples/EM/drezet_jmp_47_072901_06.pdf
- [34] C.-T. Tai, *Kirchhoff Theory: Scalar, Vector, or Dyadic?*, IEEE Trans. Ant. Prop. **20**, 114 (1972), http://physics.princeton.edu/~mcdonald/examples/EM/tai_ieetap_20_114_72.pdf
- [35] C.-T. Tai, *A Concise Formulation of Huygens' Principle for the Electromagnetic Field*, IEEE Trans. Ant. Prop. **8**, 634 (1960), http://physics.princeton.edu/~mcdonald/examples/EM/tai_iretap_8_634_60.pdf
- [36] W.R. Hamilton, *Lectures on Quaternions* (Hodge and Smith, Dublin, 1853), http://physics.princeton.edu/~mcdonald/examples/EM/hamilton_lectures_on_quaternions_53.pdf
- [37] J.W. Gibbs, *Elements of Vector Analysis* (1884), http://physics.princeton.edu/~mcdonald/examples/EM/gibbs_elements_of_vector_analysis_84.pdf
- [38] H. Bateman, *The Mathematical Analysis of Electrical and Optical Wave-Motion on the Basis of Maxwell's Equations* (Cambridge U. Press, 1915), http://physics.princeton.edu/~mcdonald/examples/EM/bateman_wave_motion_15.pdf
- [39] A.N. Sommerfeld, *Zur Relativitätstheorie. I. Vierdimensionale Vektoralgebra*, Ann. d. Phys. **32**, 749 (1910), http://physics.princeton.edu/~mcdonald/examples/EM/sommerfeld_ap_32_749_10.pdf
http://physics.princeton.edu/~mcdonald/examples/GR/sommerfeld_ap_32_749_10_english.pdf
- [40] B. Riemann, *Die Partiellen Differential-Gleichungen der Mathematischen Physik*, Vol. 2, ed. by H. Weber (Braunschweig, 1901), http://physics.princeton.edu/~mcdonald/examples/EM/weber_riemann_v2.pdf

- [41] L. Silberstein, *Elektromagnetische Grundgleichungen in bivectorieller Behandlung*, Ann. d. Phys. **22**, 579 (1907),
http://physics.princeton.edu/~mcdonald/examples/EM/silberstein_ap_22_579_07.pdf
http://physics.princeton.edu/~mcdonald/examples/EM/silberstein_ap_22_579_07_english.pdf
- [42] H. Levine and J. Schwinger, *On the Theory of Electromagnetic Wave Diffraction by an Aperture in an Infinite Plane Conducting Screen*, Comm. Pure Appl. Math. **3**, 355 (1953), http://physics.princeton.edu/~mcdonald/examples/EM/levine_cpam_3_355_50.pdf
- [43] J. Van Bladel, *Some Remarks on Green's Dyadic for Infinite Space*, IRE Trans. Ant. Prop. **9**, 563 (1961), http://physics.princeton.edu/~mcdonald/examples/EM/vanbladel_iretap_9_563_61.pdf
- [44] J.-M. Chen, *A Simple Physical Picture of Tensor Green's Function in Source Region*, Proc. IEEE **65**, 1202 (1977),
http://physics.princeton.edu/~mcdonald/examples/EM/chen_pieee_65_1202_77.pdf
- [45] J.R. Mentzner, *Scattering and Diffraction of Radio Waves* (Pergamon, London, 1955).