

Laser Beams and Resonators: The 1960s

Anthony E. Siegman, *Life Fellow, IEEE*

Invited Paper

Abstract—This paper looks back at how the basic concepts related to optical resonators and lensguides emerged during the first decade of the laser era. A subsequent paper will review the continuing developments during the three decades since then.

Index Terms—History, laser beams, optical resonators.

I. INTRODUCTION

CLASSICAL optics [1], [2] is rich in distinguished names and associated concepts: the Airy disk, Brewster's angle, Fraunhofer and Fresnel zones, Huygens' integral, Newton's rings, the Sagnac interferometer, Snell's law, not to mention more exotic examples like the Spot of Arago [3], the Gouy phase shift [4]–[6], assorted Liouville theorems, the Talbot effect [7], and that mysterious French theorist Jean-Claude Étendue. Operation of the first laser in 1960 [8] brought renewed importance to these older concepts and stimulated the development of new concepts by creative people working in this new field.

This paper looks back at how the fundamental concepts associated with the resonant modes of laser oscillators and the paraxial propagation of laser beams emerged during the first decade of the laser era. A subsequent paper will describe how these concepts have evolved in many further directions in the following three decades. Lasers have of course also had enormous impacts in spectroscopy, nonlinear optics, and the massive advances in fiber optics that are revolutionizing telecommunications today, but these topics are beyond the scope of this review.

In preparing these reviews, I have tried to cite important early papers associated with the topics I discuss. I can only hope for partial success in this, however, and must apologize in advance to contributors whom I may have overlooked. I have included every reference dealing with resonator modes known to me in the English literature through 1965, and made special efforts to cite Russian literature and contributions from outside the U.S. Anan'ev's 1992 book [9] is an additional source for such references.

Many earlier reviews are available [10]–[25], notably the personal reminiscences concerning the earliest optical resonator developments by Kompfner [26]. More details on the technical aspects of optical beams and resonators can be found in the author's lasers text [22]. An updated list of references for both of

these papers will also be placed online [27] to permit automated searching.

II. LASER RESONATORS: THE EARLY 1960S

A. Prehistory

The most important advance in optical resonators came in 1960 with the initial demonstration that open-sided optical resonators really could have distinct transverse as well as axial modes—unique eigenmodes similar though not identical to the microwave waveguide modes that were extensively studied before and during World War II. The existence of such low-loss modes, and the basic idea of using unusually narrow, unusually long optical interferometers with flat or curved mirrors as resonant feedback structures, had precursors during the late 1950s, arising out of interest in beam waveguides for millimeter-wave propagation and growing interest in laser action itself.

Early publications include a laser proposal by Prokhorov [28], [189], early laser and lensguide patents by Dicke [29] and Gobau [30], and the important early laser proposal by Schawlow and Townes [31]. (The Dicke patent, by the way, also gives a clear explanation of something very close to modern laser Q -switching.) Gobau also noted in a later round-table discussion [32] that parallel-plate resonators were investigated at microwave frequencies in 1954 by Scheiber, King, and Tatsuguchi under a Signal Corporation contract at the University of Wisconsin.

B. Fox and Li

The modern understanding of optical resonators first emerged, however, in a truly pioneering 1961 paper by Gardner Fox and Tingye Li [33], [34]. Given that Fox also served for many years as editor of the IEEE JOURNAL OF QUANTUM ELECTRONICS, dedicating this review to him seems only appropriate. The best way to summarize the new understanding contributed by this paper may be to simply reproduce its Abstract:

A theoretical investigation has been undertaken to study diffraction of electromagnetic waves in Fabry–Perot interferometers when they are used as resonators in optical masers. An electronic digital computer was programmed to compute the electromagnetic field across the mirrors of the interferometer where [when?] an initial launched wave is reflected back and forth between the mirrors.

It was found that after many reflections a state is reached in which the relative field distribution does not vary from

Manuscript received August 15, 2000.

The author is with the Edward L. Ginzton Laboratory, Stanford University, Stanford, CA 94305-4085 USA (e-mail: siegman@stanford.edu).

Publisher Item Identifier S 1077-260X(00)11492-3.

transit to transit and the amplitude of the field decays at an exponential rate. This steady-state field distribution is regarded as a normal mode of the interferometer. Many such normal modes are possible depending upon the initial wave distribution. The lowest order mode, which has the lowest diffraction loss, has a high intensity at the middle of the mirror and rather low intensities at the edges. Therefore, the diffraction loss is much lower than would be predicted for a uniform plane wave. Curves for field distribution and diffraction loss are given for different mirror geometries and different modes.

Since each mode has a characteristic loss and phase shift per transit, a uniform plane wave which can be resolved into many modes cannot, properly speaking, be resonated in an interferometer. In the usual optical interferometers, the resolution is too poor to resolve the individual mode resonances and the uniform plane wave distribution may be maintained approximately. However, in an oscillating maser, the lowest order mode should dominate if the mirror spacing is correct for resonance.

A confocal system has also been investigated and the losses are shown to be orders of magnitude less than for plane mirrors.

Fig. 1, taken from Fig. 5 of this paper, shows the steady-state or self-reproducing amplitude and phase profiles of the lowest order mode in a typical one-transverse-dimensional or strip resonator some 25 wavelengths wide and 100 wavelengths long. Note how the amplitude profile of this mode drops down to a low value near the mirror edges, and the steady-state phase profile rolls off, indicating diffractive spreading in this outer region. Note also the strong diffraction ripples caused by the finite resonator edges in the first transit, and the weaker residual ripples in the final mode profile.

Fig. 2, reproduced from the same paper, shows how the wave amplitude at one point on the mirror oscillates on successive round trips as the iterative calculation process nears convergence. The periodic ringing represents interference or transverse mode beating caused by the different round-trip phase shifts or phase velocities of the two lowest loss modes, while the exponential decay shows how the next higher loss mode dies out relative to the lowest loss mode. A hundred or more round trips are required to reach this point in the case at hand, because the losses for still higher order modes are also small and so the higher order modes are only slowly stripped out of the computation.

Fox and Li were not sure at the time they initiated this investigation that open-sided resonators would have modes such as these [35], and some of their Bell Labs colleagues are said to have argued that no such modes would exist [26]. But as they state in the final section of their first paper:

Diffraction calculations carried out on the IBM computer have led to the following conclusions:

- 1) Fabry-Perot interferometers, whether of the plane or concave mirror type, are characterized by a discrete set of normal modes which can be defined on an iterative basis. The dominant mode has a field intensity which falls to low values at the edges of the mirrors, thereby causing the power loss due to diffrac-

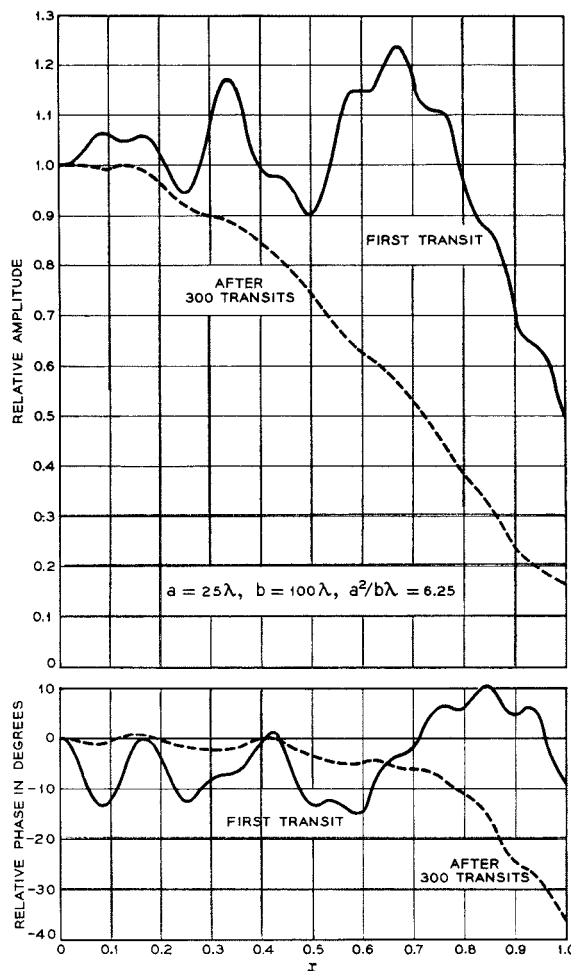

Fig. 1. Transverse amplitude and phase profiles for the lowest loss mode of a planar strip resonator with planar mirrors (from Fox and Li, 1961).

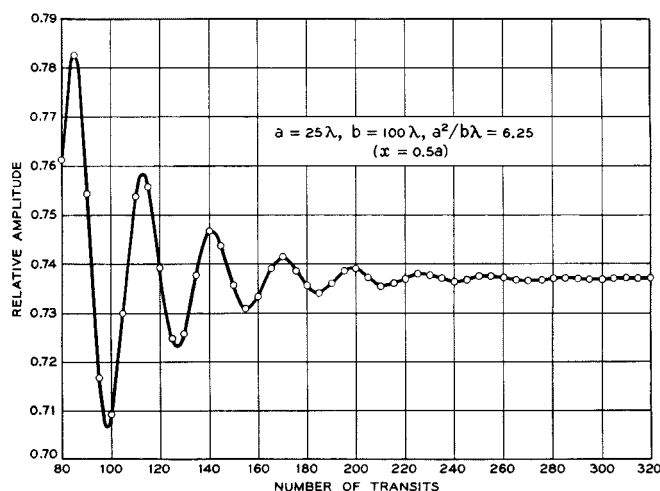

Fig. 2. Convergence of a typical Fox and Li iterative calculation to steady state, showing how the next higher order mode slowly dies out after many round trips.

tive spillover to be much lower than would be predicted on the assumption of uniform plane wave excitation.

(There is an interesting slip of the pen in this paragraph and in the Abstract, since Fox and Li note elsewhere that their modes are not orthogonal and hence not “normal modes” in the usual sense of that term.)

Fox and Li’s numerical approach provides a procedure for finding the resonator eigenmodes that is equivalent to the so-called power method for finding the largest eigenvalue of a complex matrix. Other methods for finding resonator eigenmodes have since been developed, but the Fox and Li method remains widely used even today, although more modern fast Fourier transform methods are usually employed for the round-trip propagation. Their approach draws much of its strength from how closely it mimics what really happens in an oscillating laser—that is, buildup of the lowest loss transverse mode or modes, accompanied by the stripping out of higher order modes as the laser radiation travels around repeatedly within the laser cavity. The fact that many Fox and Li calculations are started from random initial values for the wavefront amplitude at each transverse point even mimics to some extent the fact that real lasers in many cases build up from random spontaneous emission noise.

C. Emergence of Gaussian Mode Theory

The period immediately following the first Fox and Li papers was a time of immensely rapid progress in the understanding of optical resonators. Fox and Li considered both planar and confocal resonators, and pointed out that the modes inside an optical resonator were formally equivalent to the propagation modes of a periodically iterated lensguide or beam waveguide. During the same period, Goba and coworkers were also examining the modal properties of periodic lensguides using rather complex mathematical techniques [36], although these workers do not seem to have discussed their application to resonators.

A second very significant early paper on optical resonators by Gary Boyd and James P. Gordon [37] appeared in same March 1961 issue of the Bell System Technical Journal as the Fox and Li paper. In this paper, Boyd and Gordon showed that the exact eigenmodes of a confocal resonator with square mirrors are prolate spheroidal wavefunctions whose mathematical properties had previously been considered by their Bell Labs colleagues Slepian and Pollack [38]. The exactly confocal case with square mirrors is in fact one of the few common optical resonators for which an exact solution, including losses and mode profiles, can be given in closed form.

Boyd and Gordon then showed that these prolate spheroidal eigensolutions became Hermite–Gaussian modes in the practical limit of vanishingly small losses or large enough mirrors. They introduced the notations of w for the Gaussian spot size and b for the confocal parameter (although this parameter is now more commonly replaced by the Rayleigh range $z_R = b/2$ [39]–[41] and described how the spot size $w(z)$ and wavefront curvature $R(z)$ of the Hermite–Gaussian beams varied with distance inside and outside the resonator. They also extended their analysis to symmetric concave spherical reflectors separated by any distance up to twice their common radius of curvature and derived the spot sizes, resonant frequencies, and mode degeneracy properties for what they labeled as the TEM_{nmq} modes in these resonators.

(Many of the same results are also given in a contemporaneous analysis of optical lensguides by another Bell Labs colleague John R. Pierce [42], who in turn references similar work by Goubau and Schwering [36].)

This approach was extended the following year by Boyd and Herwig Kogelnik [43], who considered Gaussian modes in resonators with unequal radii of curvature and arbitrary mirror spacings, and interpreted their results using what we now call the resonator stability diagram (which they attributed to Fox and Li). They also described the Laguerre–Gaussian modes appropriate to mirrors with circular cross section. These two papers together put forth most of the now well-known basic properties of Gaussian modes in stable two-mirror resonators.

III. LASER RESONATORS: THE MID-1960S

A. Additional Resonator Mode Analyses

With these conceptual foundations firmly in place, Fox and Li and many others continued the exploration of resonator properties, extending their results to tilted mirrors [44]–[46], other mirror shapes [47], hole coupling [48], and the effects of gain saturation and mode deformation [49]–[51]. Streiffer showed that the Fox and Li formulation could also be efficiently solved by matrix diagonalization methods [52]–[55], and Heurtley showed that the exact prolate spheroidal solutions for square confocal mirrors could be extended to hyperspheroidal solutions for confocal circular-mirror resonators [56].

Despite the simplicity of the approximate Gaussian solutions, the exact mathematical properties of the modes of open-sided optical resonators are complex (and remain so to this day). The operator that describes the eigenmodes of such resonators is not Hermitian, and the resulting eigenmodes are in general not orthogonal, i.e., are not a set of “normal modes” in the usual sense. In fact the existence of a complete set of eigenmodes is not even guaranteed, as discussed by a number of authors [57], [58]. Variational and Schmidt approaches to the eigenmode problem were attempted by a number of authors [52], [54], [59]–[62], but criticized on fundamental grounds by Morgan [63].

A very different and apparently mathematically solid approach based on a sophisticated waveguide analysis was introduced by Vainshtein (or Weinstein) [64], [190], [65], and nicely summarized by Toraldo di Francia in a 1964 round-table discussion [66], although it does not seem to have found much practical application since then. A perturbation method valid for small mirrors or large cavity losses was also put forth by Bergstein and Schachter [67]–[69]. Additional Russian and other resonator calculations are presented in [47], [70]–[74].

B. Other Early Ideas and Experiments

This theoretical ferment was of course accompanied by rapid development of practical laser devices and structures which I will not attempt to review here, except to cite a few early observations of higher order Hermite–Gaussian and Laguerre–Gaussian modes [75]–[80], and transverse mode beats and mode degeneracies in oscillating lasers [79], [81]. Transverse mode discrimination and the suppression of higher order and parasitic modes was studied theoretically by Li [82],

[83] and explored experimentally by many workers, especially on high-gain ruby lasers [84]–[87].

The “Collins chart” for describing Gaussian beam propagation in a graphical fashion was developed by Stuart Collins and extended by others during this period [88]–[92]. The concept of Gaussian mode matching also emerged [93], [94], and Gordon and Kogelnik developed generalized equivalence relations among stable Gaussian resonators [95], [96]. Robert Pole and H. Wieder demonstrated a particularly clever and interesting conjugate–concentric resonator with concentric spherical end surfaces on the internal laser rod [97].

This era also saw the invention of the confocal scanning interferometer [98], a modern implementation of the Connes interferometer [99]–[101], which has since become of great importance as a tunable filter and optical spectrum analyzer. A small flurry of interest in passive multibounce stable resonators as optical delay lines and long-path-length spectroscopic absorption cells also led to some particularly clever experiments [102], [103].

C. The Unstable Resonator

In 1965, I introduced the so-called unstable optical resonator which has very different physical and mathematical properties compared to Gaussian stable resonators [104]. Earlier papers by Fox and Li [44], [45] had calculated a few unstable resonator cases as an aside, without recognizing their quite different basic character, and there had been a predecessors to this idea in the form of “diffraction coupling” from Fabry–Perot resonators [105], [106].

My initial paper on this topic led to a number of additional calculations [107]–[116]. The concept of the equivalent Fresnel number N_{eq} for the unstable resonator was introduced by Ray Arrathoon [114], and the importance of the confocal unstable resonator, shown in Fig. 3, and the distinction between positive-branch and negative-branch unstable resonators emerged from important early experiments by William Krupke and Walt Sooy [117].

Significant work in the Soviet Union by Anan’ev and coworkers [73], [118]–[121] included introduction of the astigmatic stable–unstable resonator, and the important concept of edge tapering of the output coupler in order to reduce or eliminate mode-crossing effects characteristic of hard-edged unstable resonators. A very different and powerful asymptotic analysis of unstable resonators was developed in 1973 by Horwitz [122] and later given a physical interpretation in terms of scattering of the magnified mode pattern on each round trip into Keller edge waves [123]–[126] at the hard edges of the output coupler. This has led to the so-called virtual source approach [127]–[131] which greatly simplifies accurate calculation of the complicated unstable resonator mode profiles [132]. The special mathematical difficulties associated with the unstable resonator were also explored in the 1970s by Landau [133], [134].

Much of this initial development is summarized in reviews by Anan’ev [15] and Siegman [17], [135]. Geometrically unstable resonators, particularly when supplemented by variable reflectivity mirror (VRM) concepts, have since become of some importance for obtaining high-power or high-energy outputs with

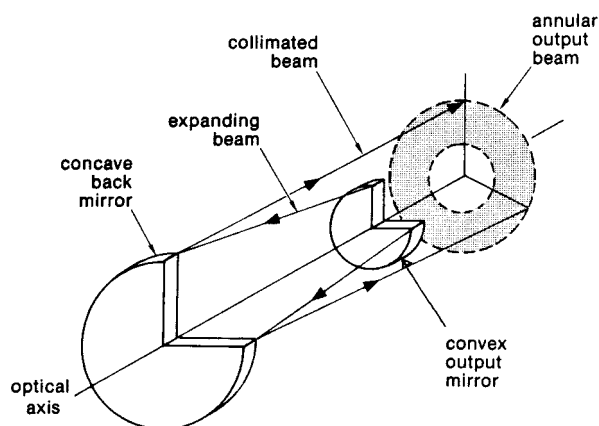

Fig. 3. Schematic drawing of a confocal hard-edged unstable resonator (from Krupke and Sooy, 1969).

good beam quality from large-volume laser media. Most recently, a group in Leiden has made the interesting discovery that the mode profiles of unstable resonators appear in fact to be fractal in character [136], [137].

D. Hole-Coupled and Roof Resonators

During the first decade of the laser era, there was also considerable interest in roof resonators with end mirrors consisting of prisms or of flat surfaces intersecting at dihedral angles. These reflectors were easy to fabricate, and offered a certain degree of alignment insensitivity in Q -switched lasers employing a spinning end mirror. Despite a considerable literature that developed during the early 1960s (cf. [138]), these resonators seem to have been a technological dead end and do not seem to have led to any particularly interesting new concepts.

Hole coupling through a small central hole in stable cavity resonators [48], [139] was also considered during this period. The idea of hole coupling seems to arise periodically in the laser field—although it is almost always a fundamentally bad idea.

E. Distributed Feedback Lasers

The concept of distributed feedback, in which the laser mirrors are replaced by distributed feedback from some form of Bragg grating distributed continuously along the length of a laser medium, was introduced in the early 1970s by Kogelnik and Shank [140]–[142] and has become of some practical importance for semiconductor lasers. I have not reviewed the extensive literature on this subject because the interesting questions focus on the longitudinal coupled-wave and laser feedback aspects rather than on transverse mode or beam propagation aspects.

F. Twisted Mode Resonators and Axial Mode Selection

Spatial hole burning associated with the axial nulls in a conventional standing-wave laser cavity favors laser operation in two or more axial modes, especially in wide-line solid-state lasers. One early and effective method for obtaining single-axial mode operation was the unidirectional ring laser [143]. Another early solution was the twisted-mode resonator [144] in which quarter-wave plates at each end of the resonator produce axial

modes in the form of twisted ribbons with constant intensity along the cavity length. This concept has subsequently found a number of other applications [145]–[149].

Other ingenious methods for obtaining single axial mode oscillation in wide-line lasers were developed during the first decade of the laser era, including multiple-mirror cavities, vernier-Michelson interferometers, Fox–Smith interferometers, White interferometers, Sagnac interferometers, and intracavity etalons. An excellent review of transverse and axial mode selection technology as of 1972 is given by Smith [150].

IV. ALSO DURING THE 1960S: OPTICAL LENS GUIDES

A. *Lensguides for Information Transmission*

Fox and Li's initial paper noted that the transverse modes of laser resonators were equivalent to the modes of periodic focusing systems or optical lensguides. The concepts of stable and unstable rays in periodic focusing systems had been developed some time earlier in connection with the focusing of electron beams [151], and the transverse modes of beam waveguides for millimeter-wave or optical wavelengths had been the subject of considerable research along a parallel but almost independent track in the late 1950s and early 1960s because of their potential for high-capacity telecommunications through underground pipes, sometimes referred to as "optical pipelines" [152].

Early references on the modes of beam waveguides include the pioneering work of Gobau and others [30], [36], [42], [152]–[157]. Experimental tests of kilometer-long optical waveguides in the mid-1960s are described by Gobau [158] and Gloge [159], [160], and reviews of this technology as of 1968 are given by Gobau [161], [162]. The emerging promise of optical fibers beginning around 1966, as pointed out by Kao in Britain [163], followed by the first demonstration of truly low-loss fibers at Corning in the early 1970s [164], [165], however, led to the rapid demise of beam waveguides as a communications medium.

B. *Gas Lenses*

There is, however, one intriguing even if dead-end technology from the beam waveguide era that seems worth mentioning. To eliminate the unacceptable losses associated with glass lenses and their imperfect optical coatings, researchers at Bell Laboratories developed "gas lenses" consisting of meter-long centimeter-diameter heated pipes or other more complex structures with cold gas flowing axially through the center, as shown in Figs. 4 and 5 [166]–[171].

The radially varying refractive index produced by colder gas on axis with heated gas surrounding it created a weak but very low-loss lens which could be employed in an optical waveguide. The need to supply electrical power (or hot water) to heat the surrounding structure led to the intriguing figure of merit for these lenses of "diopters per kilowatt."

V. SUMMARY

All the basic concepts associated with real stable resonators and real Gaussian beams were in place by the middle 1960s, as documented in Kogelnik and Li's classic review [10] and in

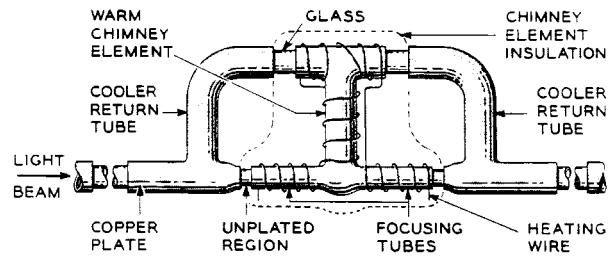

Fig. 4. Schematic drawing of a flowing gas lens [168].

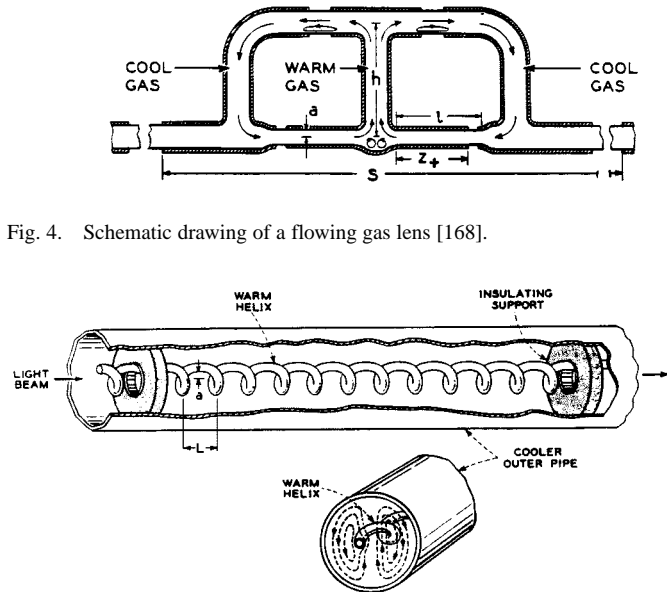

Fig. 5. Helical convective gas lens [168].

the revised (1965) edition of Ramo, Whinnery, and van Duzer's classic text [172]. Real ray matrices, already known in standard optics texts [173], had been applied to optical resonators [70], [174]–[179] and converted to the now standard ABCD notation [102], [180]–[182]. Kogelnik in particular [180] had identified the bilinear transformation of the complex \tilde{q} parameter through any paraxial optical system using the ABCD matrix. The historical connection between the differential phase shifts of Gaussian modes and the Gouy phase shift of the 19th century [4]–[6], [183], [184] was recognized, and Baues [185], [186] and Collins [187] made the important observation that Huygens' integral through a cascaded sequence of paraxial optical elements could be written as a single integral involving only the cascaded ABCD matrix of the system.

Development of new concepts and still further knowledge in optical resonators and paraxial beam propagation nonetheless continued at a rapid pace during the following decades and continues even today. These advances have been motivated by new types of lasers, by requirements for more complex and multi-element laser resonators, by advances in laser beam propagation for practical applications, and by a desire for increased basic understanding of optical beams and resonators. The most notable of the further developments in these areas occurring after the mid-to-late 1960s are described in the immediately following paper [188].

Note Added in Proof

Patent decisions in recent years have also brought increased visibility to an early conception and description of the open-sided laser resonator recorded (along with the concept of Brewster windows for laser tubes) by Gordon Gould in a notebook prepared in November 1957. This notebook has since become the foundation for several extensively litigated and eventually validated U.S. patents. A recent narrative of these events is given by Nick Taylor in *LASER: The Inventor, the Nobel Laureate, and the Thirty-Year Patent War* (New York: Simon and Schuster, 2000).

REFERENCES

- [1] O. S. Heavens and R. W. Ditchburn, *Insight into Optics*. New York: Wiley, 1991.
- [2] W. Born and E. Wolf, *Principles of Optics*. New York: Pergamon, 1959.
- [3] J. E. Harvey and J. L. Forgham, "The spot of Arago: New relevance for an old phenomena," *Amer. J. Phys.*, vol. 52, pp. 243–247, Mar. 1984.
- [4] L. G. Gouy, "Sur une propreite nouvelle des ondes lumineuses," *Comput. Rendue Acad. Sci. Paris*, vol. 110, pp. 1251–1253, 1890.
- [5] —, "Sur la propagation anormale des ondes," *Compt. Rendue Acad. Sci. Paris*, vol. 111, p. 33, 1890.
- [6] F. Reiche, "Über die anomale Fortpflanzung von Kugelwellen beim Durchgang durch Brennpunkte," *Ann. der Physik*, vol. 27, pp. 65–93, 1909.
- [7] K. Patorski, "The self imaging phenomenon and its applications," in *Progress in Optics*, E. Wolf, Ed. Amsterdam, The Netherlands: North-Holland, 1989, pp. 1–108.
- [8] T. H. Maiman, "Stimulated optical radiation in ruby," *Nature*, vol. 187, p. 493, 1960.
- [9] Y. A. Anan'ev, *Laser Resonators and the Beam Divergence Problem*. New York: Institute of Physics Publishing, 1992.
- [10] H. Kogelnik and T. Li, "Laser beams and resonators," *Appl. Opt.*, vol. 5, pp. 1550–1567, Oct. 1966.
- [11] H. Kogelnik, "Modes in optical resonators," in *Lasers*, A. K. Levine, Ed. New York: Marcel Dekker, 1966.
- [12] G. Toraldo di Francia, "Optical resonators," *Optica Acta*, vol. 13, p. 323, 1966.
- [13] Koppelman, "Multiple beam interference and natural modes in open resonators," in *Progress in Optics*, E. Wolf, Ed. Amsterdam, The Netherlands: North-Holland, 1967, vol. 7, pp. 3–66.
- [14] T. Li and H. Kogelnik, "Beams, modes and resonators," in *CRC Laser Handbook*, R. J. Pressley, Ed. New York: Chemical Rubber Company, 1971, pp. 421–441.
- [15] Y. A. Anan'ev, "Unstable resonators and their applications," *Sov. J. Quantum Electron.*, vol. 1, pp. 565–586, May/June 1972.
- [16] J. A. Arnaud, "Hamiltonian theory of beam mode propagation," in *Progress in Optics*, E. Wolf, Ed. Amsterdam, The Netherlands: North-Holland, 1973, vol. 11, pp. 247–304.
- [17] A. E. Siegman, "Unstable optical resonators," *Appl. Opt.*, vol. 13, pp. 353–367, Feb. 1974.
- [18] J. A. Arnaud, *Beam and Fiber Optics*. New York: Academic, 1976.
- [19] A. M. Goncharenko, *Gaussovy Puchki Sveta (Gaussian Light Beams)*: Nauka i Tekhnika, 1971.
- [20] H. Fang, *Optical Resonator Theory*. New York: Science Press, 1981.
- [21] Y. A. Anan'ev, *Resonateurs Optiques et Probleme de Divergence du Rayonnement Laser*: Editions Mir, 1982.
- [22] A. E. Siegman, *Lasers*. New York: University Science Books, 1986.
- [23] P. P. Pashinin, *Formation and Control of Optical Wavefronts*. Commack, NY: Nova Science Publishers, 1989.
- [24] D. R. Hall and P. E. Jackson, Eds., *The Physics and Technology of Laser Resonators*. New York: Adam Hilger, 1989.
- [25] N. Hodgson and H. Weber, *Optical Resonators*. New York: Springer-Verlag, 1997.
- [26] R. Kompfner, "Optics at Bell Laboratories—Optical communications," *Appl. Opt.*, vol. 11, pp. 2412–2425, Nov. 1972.
- [27] A. E. Siegman. (2000) Laser beams and resonators. Stanford Univ., Stanford, CA. [Online]. Available: <http://www-ee.Stanford.edu/siegman/>
- [28] A. M. Prokhorov, "Molecular amplifier and generator for submillimeter waves," *Sov. Phys. JETP*, vol. 7, pp. 1140–1141, Dec. 1958.
- [29] R. H. Dicke, "Molecular amplification and generation systems and methods," U.S. Patent 2 851 652, filing date May 21, 1956, issued Sept. 9, 1958.
- [30] G. J. E. Gobau, "Transmission of electromagnetic wave beams," U.S. Patent 3 101 472, filing date Nov. 21, 1958, issued Aug. 20, 1963.
- [31] A. L. Schawlow and C. H. Townes, "Infrared and optical masers," *Phys. Rev.*, vol. 112, pp. 1940–1949, Dec. 1958.
- [32] G. J. E. Gobau, "Round-table discussion on resonators," in *Quasi Optics (Proc. Symp. Quasi Optics)*, J. Fox, Ed. New York: Polytechnic Institute of Brooklyn Press, 1964, pp. 397–398.
- [33] A. G. Fox and T. Li, "Resonant modes in a maser interferometer," *Bell Syst. Tech. J.*, vol. 40, pp. 453–458, Mar. 1961.
- [34] —, "Resonant modes in an optical maser," in *Proc. IRE*, vol. 48, Nov. 1960, pp. 1904–1905.
- [35] D. A. Kleinman and P. P. Kisliuk, "Discrimination against unwanted orders in the Fabry–Perot resonator," *Bell Syst. Tech. J.*, vol. 41, p. 453, 1962.
- [36] G. J. E. Gobau and F. Schwing, "On the guided propagation of electromagnetic wave beams," *IEEE Trans. Antennas Propagat.*, vol. AP-9, pp. 248–255, May 1961.
- [37] G. D. Boyd and J. P. Gordon, "Confocal multimode resonator for millimeter through optical wavelength masers," *Bell Syst. Tech. J.*, vol. 40, pp. 489–508, Mar. 1961.
- [38] D. Slepian and H. O. Pollack, "Prolate spheroidal wave functions, Fourier analysis, and uncertainty," *Bell Syst. Tech. J.*, vol. 40, pp. 43–64, Jan. 1961.
- [39] J. W. L. R. Strutt, "On images formed with or without reflection or refraction," *Philos. Mag.*, vol. 11, pp. 214–218, 1881.
- [40] —, "On pinhole photography," *Philos. Mag.*, vol. 31, pp. 87–89, 1891.
- [41] J. F. Ramsay, "Tubular beams from radiating apertures," in *Advances in Microwaves*, L. F. Young, Ed. New York: Academic, 1968, vol. 3, p. 127.
- [42] J. R. Pierce, "Modes in sequences of lenses," in *Proc. Natl. Acad. Sci.*, vol. 47, 1961, pp. 1808–1813.
- [43] G. D. Boyd and H. Kogelnik, "Generalized confocal resonator theory," *Bell Syst. Tech. J.*, vol. 41, pp. 1347–1369, July 1962.
- [44] A. G. Fox and T. Li, "Modes in a maser interferometer with curved and tilted mirrors," *Proc. IEEE*, vol. 51, pp. 80–89, Jan. 1963.
- [45] —, "Modes in a maser interferometer with curved mirrors," in *Quantum Electronics III*, P. Grivet and N. Bloembergen, Eds. New York: Columbia Univ. Press, 1964, pp. 1263–1270.
- [46] G. Kotik and M. C. Newstein, "Theory of laser oscillations in Fabry–Perot resonators," *J. Appl. Phys.*, vol. 32, pp. 178–186, Feb. 1961.
- [47] V. O. Galeta, S. F. Dyubko, V. V. Kamyshan, and R. A. Valitov, "Diffraction losses of an open resonator formed by circular spherical mirrors," *Sov. Phys.—Tech. Phys.*, vol. 12, pp. 1633–1634, June 1968.
- [48] D. E. McCumber, "Eigenmodes of a symmetric cylindrical confocal laser resonator and their perturbation by output-coupling apertures," *Bell Syst. Tech. J.*, vol. 44, pp. 333–363, Feb. 1965.
- [49] H. Stutz and C. L. Tang, "Problem of mode deformation in optical masers," *J. Appl. Phys.*, vol. 36, pp. 1816–1819, June 1965.
- [50] T. Li and J. G. Skinner, "Oscillating modes in ruby lasers with nonuniform pumping energy distribution," *J. Appl. Phys.*, vol. 36, pp. 2595–2596, Aug. 1965.
- [51] A. G. Fox and T. Li, "Effect of gain saturation on the oscillating modes of optical masers," *IEEE J. Quantum Electron.*, vol. QE-2, pp. 774–783, Dec. 1966.
- [52] W. Streifer, "Modes in spherical resonators with rectangular mirrors," *J. Opt. Soc. Amer.*, vol. 54, p. 1399, Nov. 1964.
- [53] J. C. Heurtley and W. Streifer, "Optical resonator modes—Circular reflectors of spherical curvature," *J. Opt. Soc. Amer.*, vol. 55, pp. 1472–1479, Nov. 1965.
- [54] W. Streifer, "On the integral equation for Fabry–Perot interferometer modes," *Phys. Lett.*, vol. 18, pp. 118–119, Aug. 1965.
- [55] —, "Optical resonator modes—Rectangular reflectors of spherical curvature," *J. Opt. Soc. Amer.*, vol. 55, pp. 868–877, July 1965.
- [56] J. C. Heurtley, "Hyperspheroidal functions—Optical resonators with circular mirrors," in *Quasi Optics (Proc. Symp. Quasi Optics)*, J. Fox, Ed. New York: Polytechnic Institute of Brooklyn Press, 1964, pp. 367–375.
- [57] D. J. Newman and S. P. Morgan, "Existence of eigenvalues of a class of integral equations arising in laser theory," *Bell Syst. Tech. J.*, vol. 43, pp. 113–126, Jan. 1964.
- [58] J. A. Cochran, "The existence of eigenvalues for the integral equations of laser theory," *Bell Syst. Tech. J.*, vol. 44, pp. 77–88, Jan. 1965.

- [59] C. L. Tang, "On diffraction losses in laser interferometers," *Appl. Opt.*, vol. 1, pp. 768–770, Nov. 1962.
- [60] S. R. Barone, "Resonances of the Fabry–Perot etalon," *J. Appl. Phys.*, vol. 34, pp. 831–843, Apr. 1963.
- [61] H. Gamo, "Round-table discussion on resonators," in *Quasi Optics (Proc. Symp. Quasi Optics)*, J. Fox, Ed. New York: Polytechnic Institute of Brooklyn Press, 1964, pp. 402–406.
- [62] W. Streifer and H. Gamo, "On the Schmidt expansion for optical resonator modes," in *Quasi Optics (Proc. Symp. Quasi Optics)*, J. Fox, Ed. New York: Polytechnic Institute of Brooklyn Press, 1964, pp. 351–365.
- [63] S. P. Morgan, "On the integral equations of laser theory," *IEEE Trans. Microwave Theory Tech.*, vol. MTT-11, pp. 191–193, May 1963.
- [64] L. A. Vainshtein, "Open resonators for lasers," *Sov. Phys.—JETP*, vol. 17, pp. 709–719, Sept. 1963.
- [65] L. A. Vainshtein (Weinstein), *Open Resonators and Open Waveguides*: Golem Press, 1969.
- [66] G. Toraldo di Francia, "Round-table discussion on resonators," in *Quasi Optics (Proc. Symp. Quasi Optics)*, J. Fox, Ed. New York: Polytechnic Institute of Brooklyn Press, 1964, pp. 410–411.
- [67] L. Bergstein and H. Schachter, "Resonant modes of optical interferometer cavities—I: Plane parallel end reflectors," *J. Opt. Soc. Amer.*, vol. 54, pp. 887–903, July 1964.
- [68] H. Schachter and L. Bergstein, "Resonant modes of optic cavities with inhomogeneous host media," *J. Opt. Soc. Amer.*, vol. 54, p. 567, Apr. 1964.
- [69] L. Bergstein and H. Schachter, "Resonant modes of optic cavities of small Fresnel numbers," *J. Opt. Soc. Amer.*, vol. 55, pp. 1226–1233, Oct. 1965.
- [70] V. P. Byhov and L. A. Vainshtein, "Geometrical optics of open resonators," *Sov. Phys.—JETP*, vol. 20, pp. 338–344, Feb. 1965.
- [71] N. Karube, "Calculated divergence of laser beam from generalized spherical mirror cavities," *Proc. IEEE*, vol. 52, pp. 327–328, Mar. 1964.
- [72] P. O. Clark, "A self-consistent field analysis of spherical-mirror Fabry–Perot resonators," *Proc. IEEE*, vol. 53, p. 36, Jan. 1965.
- [73] Y. A. Anan'ev, N. A. Svetsitskaya, and V. E. Sherstobitov, "Transverse mode selection in a laser with convex mirrors," *Sov. Phys.—Dokl.*, vol. 13, pp. 351–352, Oct. 1968.
- [74] V. F. Boitsov and E. E. Fradkin, "Diffraction effects in confocal and semiconfocal resonators," *Opt. Spectros. (USSR)*, vol. 24, p. 409, 1968.
- [75] H. Kogelnik and W. W. Rigrod, "Visual display of isolated optical resonator modes," in *Proc. IRE*, vol. 50, 1962, p. 220.
- [76] J. Haisma and H. De Lang, "Mode patterns obtained by tuning a small gas laser," *Phys. Lett.*, vol. 3, pp. 240–242, Jan. 15, 1963.
- [77] H. Boersch, G. Herziger, S. Maslowski, and H. Weber, "Reproduzierbare wellenformen niedriger ordnung beim rubinlaser," *Phys. Lett.*, vol. 4, pp. 86–88, Mar. 15, 1963.
- [78] W. W. Rigrod, "Isolation of axi-symmetrical optical-resonator modes," *Appl. Phys. Lett.*, vol. 2, pp. 51–53, Feb. 1, 1963.
- [79] J. P. Goldsborough, "Beat frequencies between modes of a concave-mirror optical resonator," *Appl. Opt.*, vol. 3, pp. 267–275, Feb. 1964.
- [80] D. C. Sinclair and T. H. E. Cottrell, "Transverse mode structure in unstable optical resonators," *Appl. Opt.*, vol. 6, pp. 845–849, May 1967.
- [81] G. O. Harding and T. Li, "Effect of mode degeneracy on output of gaseous optical masers," *J. Appl. Phys.*, vol. 35, pp. 475–478, Mar. 1964.
- [82] T. Li, "Mode selection in an aperture-limited concentric maser interferometer," *Bell Syst. Tech. J.*, vol. 42, pp. 2609–2620, Nov. 1963.
- [83] —, "Diffraction loss and selection of modes in maser resonators with circular mirrors," *Bell Syst. Tech. J.*, vol. 44, pp. 917–932, May/June 1965.
- [84] J. M. Burch, "Ruby masers with afocal resonators," *J. Opt. Soc. Amer.*, vol. 52, p. 602, May 1962.
- [85] J. A. Baker and C. W. Peters, "Mode selection and enhancement with a ruby laser," *Appl. Opt.*, vol. 1, p. 674, Sept. 1962.
- [86] J. G. Skinner and J. E. Geusic, "Diffraction-limited ruby oscillator," *J. Opt. Soc. Amer.*, vol. 52, p. 1319, Nov. 1962.
- [87] R. J. Collins and J. A. Giordmaine, "New modes of optical oscillation in closed resonators," in *Quantum Electronics III*, P. Grivet and N. Bloembergen, Eds. New York: Columbia Univ. Press, 1964, p. 1239.
- [88] S. A. Collins, "Analysis of optical resonators involving focusing elements," *Appl. Opt.*, vol. 3, pp. 1263–1275, Nov. 1964.
- [89] T. Li, "Dual forms of the Gaussian beam chart," *Appl. Opt.*, vol. 3, pp. 1315–1317, Nov. 1964.
- [90] J. P. Gordon, "A circle diagram for optical resonators," *Bell Syst. Tech. J.*, vol. 43, pp. 1826–1827, Nov. 1964.
- [91] T. S. Chu, "Geometrical representation of Gaussian beam propagation," *Bell Syst. Tech. J.*, vol. 45, pp. 287–299, Feb. 1966.
- [92] P. Laues, "Geometrical approach to Gaussian beam propagation," *Appl. Opt.*, vol. 6, pp. 747–755, Apr. 1967.
- [93] H. Kogelnik, "Matching of optical modes," *Bell Syst. Tech. J.*, vol. 43, pp. 334–337, Jan. 1964.
- [94] —, "Coupling and conversion coefficients for optical modes," in *Quasi Optics (Proc. Symp. Quasi Optics)*, J. Fox, Ed. New York: Polytechnic Institute of Brooklyn Press, 1964, pp. 333–347.
- [95] J. P. Gordon and H. Kogelnik, "Equivalence relations among spherical mirror optical resonators," *Bell Syst. Tech. J.*, vol. 43, pp. 2873–2886, Nov. 1964.
- [96] D. C. Sinclair, "Choice of mirror curvatures for gas laser cavities," *Appl. Opt.*, vol. 3, p. 1067, Sept. 1964.
- [97] R. V. Pole and H. Wieder, "Continuous operation of a ruby laser during pumping pulse," *Appl. Opt.*, vol. 3, pp. 1086–1087, Sept. 1964.
- [98] R. L. Fork, D. Herriott, and H. Kogelnik, "A scanning spherical mirror interferometer for spectral analysis of laser radiation," *Appl. Opt.*, vol. 3, pp. 1471–1484, Dec. 1964.
- [99] P. Connes, "Increase of the product of luminosity and resolving power of interferometers by using a path difference independent of the angle of incidence," *Revue d'Optique*, vol. 35, p. 37, 1952.
- [100] —, "Increase of the product of luminosity and resolving power of interferometers by using a path difference independent of the angle of incidence," *J. Phys. Radium*, vol. 19, pp. 2262–269, 1958.
- [101] R. W. Zimmerman, "Spherical mirror Fabry–Perot resonators," *IRE Trans. Microwave Theory Tech.*, vol. 11, pp. 371–379, Sept. 1963.
- [102] D. Herriott, H. Kogelnik, and R. Kompfner, "Off-axis paths in spherical mirror interferometers," *Appl. Opt.*, vol. 3, pp. 523–526, Apr. 1964.
- [103] D. Herriott and H. J. Schulte, "Folded optical delay lines," *Appl. Opt.*, vol. 4, pp. 883–889, Aug. 1965.
- [104] A. E. Siegman, "Unstable optical resonators for laser applications," *Proc. IEEE*, vol. 53, pp. 277–267, Mar. 1965.
- [105] J. T. LaTourrette, S. F. Jacobs, and P. Rabinowitz, "Improved laser angular brightness through diffraction coupling," *Appl. Opt.*, vol. 3, pp. 981–982, Aug. 1964.
- [106] L. F. Mollenauer *et al.*, "The high-gain laser as a wavelength standard," in *Optical Masers*, J. Fox *et al.*, Eds. New York: Polytechnic Institute of Brooklyn Press, 1964, p. 51.
- [107] W. K. Kahn, "Unstable optical resonators," *Appl. Opt.*, vol. 5, pp. 407–413, Mar. 1966.
- [108] S. R. Barone, "Optical resonators in the unstable region," *Appl. Opt.*, vol. 6, pp. 861–863, May 1967.
- [109] L. Bergstein, "Modes of stable and unstable optical resonators," *Appl. Opt.*, vol. 7, pp. 495–504, Mar. 1968.
- [110] R. L. Sanderson and W. Streifer, "Unstable laser resonator modes," *Appl. Opt.*, vol. 8, pp. 2129–2136, Oct. 1969.
- [111] —, "Laser resonators with tilted reflectors," *Appl. Opt.*, vol. 8, pp. 2241–2248, Nov. 1969.
- [112] C. R. Bisio and L. Ronchi, "Some considerations about the diffraction loss of open resonators," *IEEE Trans. Microwave Theory Tech.*, vol. MTT-19, pp. 490–491, May 1971.
- [113] A. N. Chester, "Mode selectivity and mirror misalignment effects in unstable laser resonators," *Appl. Opt.*, vol. 11, pp. 2584–2590, Nov. 1972.
- [114] A. E. Siegman and R. Arrathoon, "Modes in unstable optical resonators and lens waveguides," *IEEE J. Quantum Electron.*, vol. QE-3, pp. 156–163, Apr. 1967.
- [115] A. E. Siegman and H. Y. Miller, "Unstable optical resonator loss calculations using the Prony method," *Appl. Opt.*, vol. 9, pp. 2729–2763, Dec. 1970.
- [116] A. E. Siegman, "A canonical formulation for multi-element unstable resonator calculations," *IEEE J. Quantum Electron.*, vol. QE-12, p. 35, Jan. 1976.
- [117] W. F. Krupke and W. R. Sooy, "Properties of an unstable confocal resonator CO₂ laser system," *IEEE J. Quantum Electron.*, vol. QE-5, pp. 575–586, Dec. 1969.
- [118] Y. A. Anan'ev, N. A. Svetsitskaya, and V. E. Sherstobitov, "Properties of a laser with an unstable resonator," *Sov. Phys.—JETP*, vol. 28, pp. 69–74, Jan. 1969.
- [119] Y. A. Anan'ev, G. N. Vinokurov, L. V. Koval'chuk, N. A. Svetsitskaya, and V. E. Sherstobitov, "Telescopic-resonator laser," *Sov. Phys.—JETP*, vol. 31, pp. 420–424, Sept. 1970.
- [120] Y. A. Anan'ev and V. E. Sherstobitov, "Influence of the edge effects on the properties of unstable resonators," *Sov. J. Quantum Electron.*, vol. 1, pp. 263–267, Nov/Dec. 1971.

- [121] Y. A. Anan'ev, V. N. Chernov, and V. E. Sherstobitov, "Solid laser with a high spatial coherence of radiation," *Sov. J. Quantum. Electron.*, vol. 1, pp. 403–404, Jan./Feb. 1972.
- [122] P. Horwitz, "Asymptotic theory of unstable resonator modes," *J. Opt. Soc. Amer.*, vol. 63, pp. 1528–1543, Dec. 1973.
- [123] J. B. Keller, "Diffraction by an aperture—I," *J. Appl. Phys.*, vol. 28, pp. 426–444, Apr. 1957.
- [124] J. B. Keller, R. M. Lewis, and B. D. Seckler, "Diffraction by an aperture—II," *J. Appl. Phys.*, vol. 28, pp. 570–579, May 1957.
- [125] J. B. Keller, "A geometrical theory of diffraction," in *Proc. Symp. Appl. Math.*, vol. 8, 1958, pp. 27–52.
- [126] —, "Geometrical theory of diffraction," *J. Opt. Soc. Amer.*, vol. 52, pp. 116–119, Feb. 1962.
- [127] G. T. Moore and R. J. McCarthy, "Theory of modes in a loaded strip confocal unstable resonator," *J. Opt. Soc. Amer.*, vol. 67, pp. 228–241, Feb. 1977.
- [128] R. R. Butts and P. V. Avizonis, "Asymptotic analysis of unstable laser resonators with circular mirrors," *J. Opt. Soc. Amer.*, vol. 68, pp. 1072–1078, Aug. 1978.
- [129] W. H. Southwell, "Asymptotic solution of the Huygens–Fresnel integral in circular coordinates," *Opt. Lett.*, vol. 3, pp. 100–102, Sept. 1978.
- [130] —, "Virtual-source theory of unstable resonator modes," *Opt. Lett.*, vol. 6, pp. 487–489, Oct. 1981.
- [131] —, "Unstable-resonator-mode derivation using virtual-source theory," *J. Opt. Soc. Amer. A, Opt. Image Sci.*, vol. 3, pp. 1885–1891, Nov. 1986.
- [132] J.-L. Doumont, "Laser beam and resonator calculations on desktop computers," Ph.D. dissertation, Department of Applied Physics, Stanford Univ., Stanford, CA, June 1991.
- [133] H. J. Landau, "Loss in unstable resonators," *J. Opt. Soc. Amer.*, vol. 66, pp. 525–529, June 1976.
- [134] —, "The notation of approximate eigenvalues applies to an integral equations of laser theory," *Q. Appl. Math.*, pp. 165–173, Apr. 1977.
- [135] A. E. Siegman, "This week's citation classic," *Current Contents*, vol. 35, p. 16, Aug. 27, 1979.
- [136] G. P. Karman and J. P. Woerdman, "Fractal structure of eigenmodes of unstable-cavity resonators," *Opt. Lett.*, vol. 23, pp. 1909–1911, Dec. 15, 1998.
- [137] G. P. Karman, G. S. McDonald, G. H. C. New, and J. P. Woerdman, "Fractal modes in unstable resonators," *Nature*, vol. 402, p. 138, Nov. 11, 1999.
- [138] W. K. Kahn, "Dihedral optical resonators and prism beam waveguides," *Appl. Opt.*, vol. 6, pp. 865–872, May 1967.
- [139] J. M. Moran, "Coupling of power from a circular confocal laser with an output aperture," *IEEE J. Quantum Electron.*, vol. QE-6, p. 93, 1970.
- [140] H. Kogelnik and C. V. Shank, "Stimulated emission in a periodic structure," *Appl. Phys. Lett.*, vol. 18, pp. 152–154, 1971.
- [141] C. V. Shank, J. E. Bjorkholm, and H. Kogelnik, "Tunable distributed feedback dye laser," *Appl. Phys. Lett.*, vol. 18, pp. 395–396, 1971.
- [142] H. Kogelnik and C. V. Shank, "Coupled-wave theory of distributed feedback lasers," *J. Appl. Phys.*, vol. 43, pp. 2327–2335, 1972.
- [143] C. L. Tang, H. Statz, and G. deMars Jr., "Spectral output and spiking behavior of solid-state lasers," *J. Appl. Phys.*, vol. 34, pp. 2289–2295, Aug. 1963.
- [144] A. E. Siegman and V. Evtuhov, "Twisted-mode technique for obtaining axially uniform energy density in a laser cavity," *Appl. Opt.*, vol. 4, p. 142, Jan. 1965.
- [145] A. Kastler, "Champ lumineux stationnaire a structure helicoidale dans une cavite laser," *C. R. Acad. Sci. Paris B*, vol. 271, p. 999, 1970.
- [146] A. Draeger, "Efficient single-longitudinal-mode Nd:YAG laser," *IEEE J. Quantum Electron.*, vol. QE-8, pp. 235–239, 1972.
- [147] D. J. De Jong and D. Andreou, "An Nd:YAG laser whose active medium experiences no hole-burning effects," *Opt. Commun.*, vol. 22, pp. 138–141, 1977.
- [148] K. Wallmeroth, "Monolithic integrated Ng:YAG laser," *Opt. Lett.*, vol. 15, pp. 903–905, Aug. 15, 1990.
- [149] C. S. Adams, J. Vorberg, and I. Mlynek, "Single-frequency operation of a diode-pumped lanthanum–neodymium–hexaaluminate laser by using a twisted-mode cavity," *Opt. Lett.*, vol. 18, pp. 420–422, Mar. 15, 1993.
- [150] P. W. Smith, "Mode selection in lasers," *Proc. IEEE*, vol. 60, pp. 442–440, Apr. 1972.
- [151] J. R. Pierce, *Theory and Design of Electron Beams*. New York: Van Nostrand, 1954.
- [152] C. C. Eaglesfield, "Optical pipeline: A tentative assessment," *Proc. IEE*, vol. 109B, pp. 26–32, Jan. 1962.
- [153] J. R. Christian and G. J. E. Gobau, "Experimental studies on a beam waveguide for millimeter waves," *IEEE Trans. Antennas Propagat.*, vol. AP-9, pp. 256–263, May 1961.
- [154] F. Schwering, "Reiterative wave beams of rectangular symmetry," *Arch. Elektr. Uebertrag.*, vol. 15, pp. 555–564, Dec. 1961.
- [155] J. Hirano and Y. Fukatsu, "Stability of a light beam in a beam waveguide," *Proc. IEEE*, vol. 52, pp. 1284–1292, Nov. 1964.
- [156] E. A. Marcatilli, "Modes in a sequence of thick astigmatic lens-like focusers," *Bell Syst. Tech. J.*, vol. 43, pp. 2887–2903, 1964.
- [157] K. Miyamoto, "Propagation of laser light," *J. Opt. Soc. Amer.*, vol. 54, pp. 989–991, Aug. 1964.
- [158] G. J. E. Gobau and J. R. Christian, "Some aspects of beam waveguides for long-distance transmission at optical frequencies," *IEEE Trans. Microwave Theory Tech.*, vol. MTT-12, pp. 212–220, Mar. 1964.
- [159] D. Gloge, "Experiment with an underground lens waveguide," *Bell Syst. Tech. J.*, vol. 46, pp. 721–735, Apr. 1967.
- [160] D. Gloge and W. H. Steier, "Pulse shuttling in a half-mile optical lens guide," *Bell Syst. Tech. J.*, vol. 47, pp. 767–782, May/June 1968.
- [161] G. J. E. Gobau, "Beam waveguides," in *Advances in Microwaves*, L. F. Young, Ed. New York: Academic, 1968, vol. 3.
- [162] —, "Optical or quasi optical transmission schemes," in *Millimeter and Submillimeter Waves*, F. A. Benson, Ed. Iliffe Books Ltd., 1969, pp. 337–367.
- [163] C. K. Kao and G. A. Hockham, "Dielectric fiber surface waveguides for optical frequencies," *Proc. IEEE*, vol. 113, pp. 1151–1158, July 1966.
- [164] F. P. Kapron, D. B. Keck, and R. D. Maurer, "Radiation losses in glass optical waveguides," *Appl. Phys. Lett.*, vol. 17, pp. 423–425, Nov. 1970.
- [165] D. Gloge, Ed., *Optical Fiber Technology*. Piscataway, NJ: IEEE Press, 1976.
- [166] D. W. Berreman, "A lens or light guide using convectively distorted thermal gradients in gases," *Bell Syst. Tech. J.*, vol. 43, pp. 1469–1475, July 1964.
- [167] D. Marcuse and S. E. Miller, "Analysis of a tubular gas lens," *Bell Syst. Tech. J.*, vol. 43, pp. 1759–1782, July 1964.
- [168] D. W. Berreman, "Convective gas light guides or lens trains for optical beam transmission," *J. Opt. Soc. Amer.*, vol. 55, pp. 239–247, Mar. 1965.
- [169] D. Marcuse, "Properties of periodic gas lenses," *Bell Syst. Tech. J.*, vol. 44, p. 2083, Nov. 1965.
- [170] —, "Theory of a thermal gradient gas lens," *IEEE Trans. Microwave Theory Tech.*, vol. MTT-13, pp. 734–739, Nov. 1965.
- [171] P. Kaiser, "The stream guide, a simple low-loss optical guiding medium," *Bell Syst. Tech. J.*, vol. 47, pp. 761–765, May/June 1968.
- [172] S. Ramo, J. R. Whinnery, and T. van Duzer, *Fields and Waves in Communication Electronics*. New York: Wiley, 1965.
- [173] W. Brouwer, *Matrix Methods in Optical Instrument Design*. New York: W. A. Benjamin, 1964.
- [174] M. Bertolotti, "Matrix representation of the geometrical properties of open resonators," *Nuovo Cimento*, vol. 32, pp. 1242–1257, June 1964.
- [175] W. K. Kahn, "Round-table discussion on resonators," in *Quasi Optics (Proc. Symp. Quasi Optics)*, J. Fox, Ed. New York: Polytechnic Institute of Brooklyn Press, 19645, pp. 397–398.
- [176] —, "Geometric optical derivation of formula for the variation of the spot size in a spherical mirror resonator," *Appl. Opt.*, vol. 4, pp. 758–759, June 1965.
- [177] W. K. Kahn and J. T. Nemit, "Ray theory of astigmatic resonators and beam waveguides," in *Symp. Modern Optics*, J. Fox, Ed. New York: Polytechnic Institute of Brooklyn, 1967, pp. 501–526.
- [178] B. Macke, "Study of laser cavities in the approximation of geometrical optics" (in French), *J. de Phys. Appl.*, vol. 26, pp. 104A–112A, Mar. 1965.
- [179] N. Kurauchi and W. K. Kahn, "Rays and ray envelopes with stable optical resonators containing focusing media," *Appl. Opt.*, vol. 5, pp. 1023–1029, June 1966.
- [180] H. Kogelnik, "Imaging of optical modes—Resonators with internal lenses," *Bell Syst. Tech. J.*, vol. 44, pp. 455–494, Mar. 1965.
- [181] A. Nussbaum, "Teaching of advanced geometrical optics," *Appl. Opt.*, vol. 17, pp. 2128–2129, July 15, 1978.
- [182] A. Garrard and J. M. Burch, *Introduction to Matrix Methods in Optics*. New York: Wiley, 1975.
- [183] G. W. Farnell, "Measured phase distribution in the image space of a microwave lens," *Can. J. Phys.*, vol. 36, p. 935, 1958.
- [184] R. W. Boyd, "Intuitive explanation of the phase anomaly of focused light beams," *J. Opt. Soc. Amer.*, vol. 70, pp. 877–880, July 1980.
- [185] P. Baues, "The connection of geometric optics with the propagation of Gaussian beams and the theory of optical resonators," *Opto-Electron.*, vol. 1, pp. 103–118, 1969.

- [186] ———, "Huygens' principle in inhomogeneous isotropic media and a general integral equation applicable to optical resonators," *Opto-Electron.*, vol. 1, pp. 37–44, 1969.
- [187] S. A. Collins Jr., "Lens-system diffraction integral written in terms of geometrical optics," *J. Opt. Soc. Amer.*, vol. 60, pp. 1168–1177, Sept. 1970.
- [188] A. E. Siegman, "Laser beams and resonators: Beyond the 1960s," *IEEE J. Select. Topics Quantum Electron.*, vol. 6, 2000.
- [189] A. M. Prokhorov, "Molecular amplifier and generator for submillimeter waves," *JETP (USSR)*, vol. 34, pp. 1658–1659, June 1958.
- [190] L. A. Vainshtein, "Open resonators for lasers," *JETP (USSR)*, vol. 44, pp. 1050–1067, 1963.

Anthony E. Siegman (S'54–M'57–F'66–LF'95) retired at the end of 1998 from the McMurtry Chair of Engineering and Applied Physics at Stanford University, Stanford, CA. During his career at Stanford University, he made many contributions to microwave electronics, lasers, and optical resonators, as reported in some 40 dissertations, 250 scientific articles, and three books, including the widely used textbook *LASERS* (University Science Books, 1986). He served as President of the Optical Society of America during 1999, and is currently engaged in technical writing, teaching, and consulting.

Dr. Siegman was elected to the National Academy of Engineering and National Academy of Science, and awarded the Wood Prize and Ives Medal of the Optical Society of America, the Quantum Electronics Award of IEEE LEOS, and the Schawlow Medal of the Laser Institute of America.